



**Eike Stepper**

[stepper@esc-net.de](mailto:stepper@esc-net.de)  
<http://www.esc-net.de>  
<http://thegordian.blogspot.com>

**Berlin, Germany**



# Now that I've Got a Model Where's My Application?

---

**EclipseCon Europe 2012  
25.10.2012, Ludwigsburg**

---



# Now I've got a model !

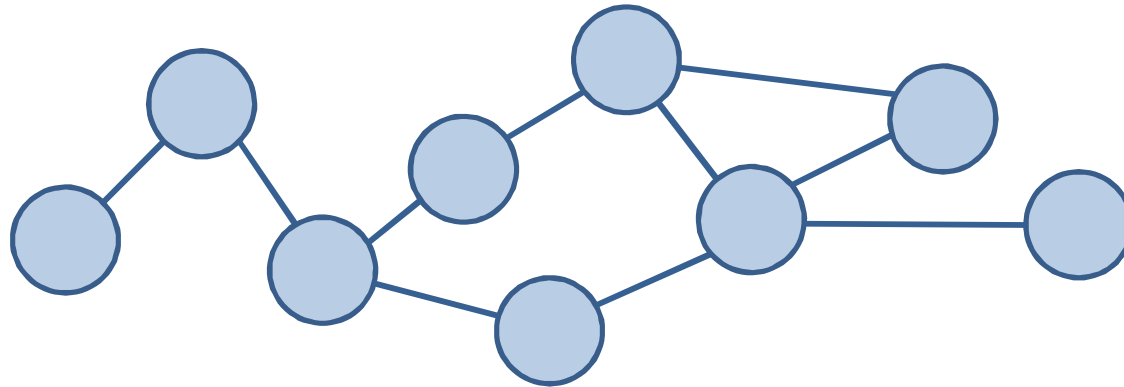

## But where's my application?

# User Interface

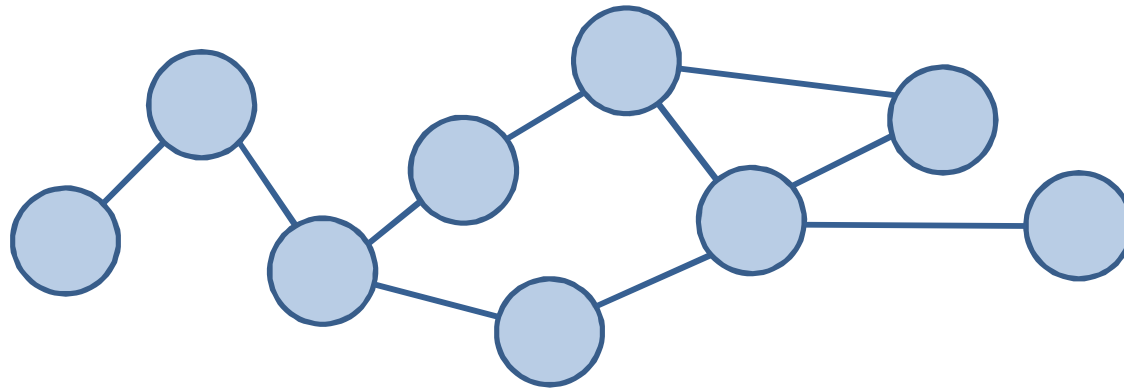

# Storage Layer

# User Interface

```
interface Resource.Factory
{
    Resource createResource(URI uri);
}
```



Resource Set

# User Interface

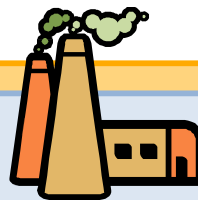
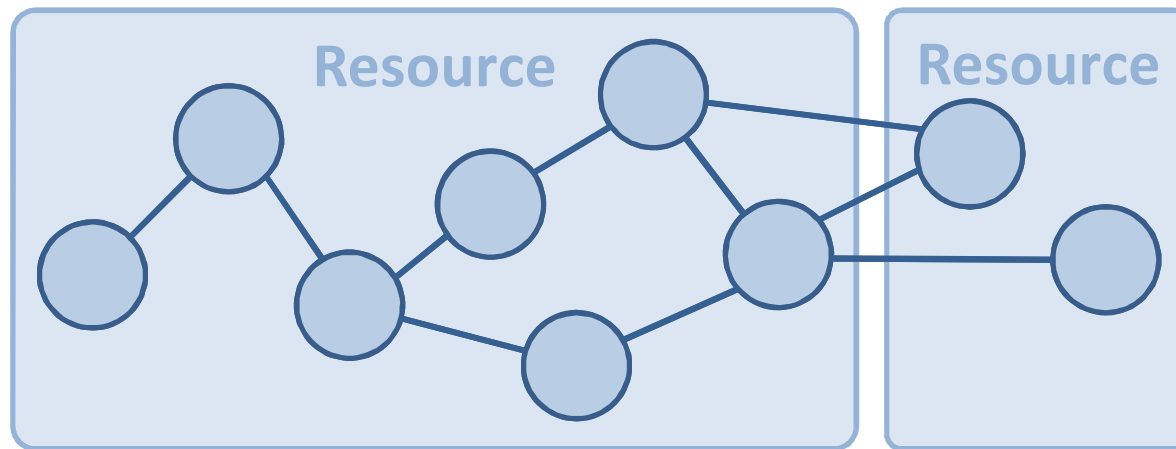

Resource Set

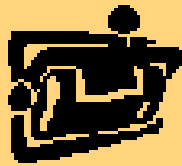

## User Interface

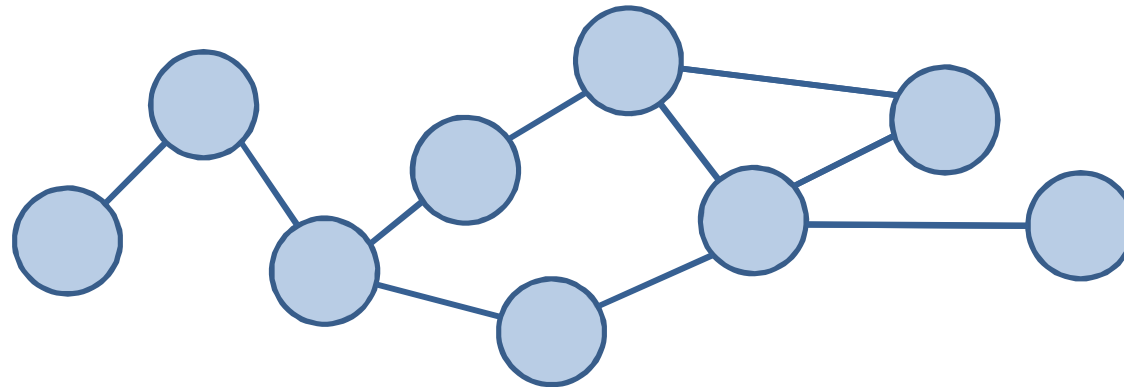

## Resource Set

# User Interface

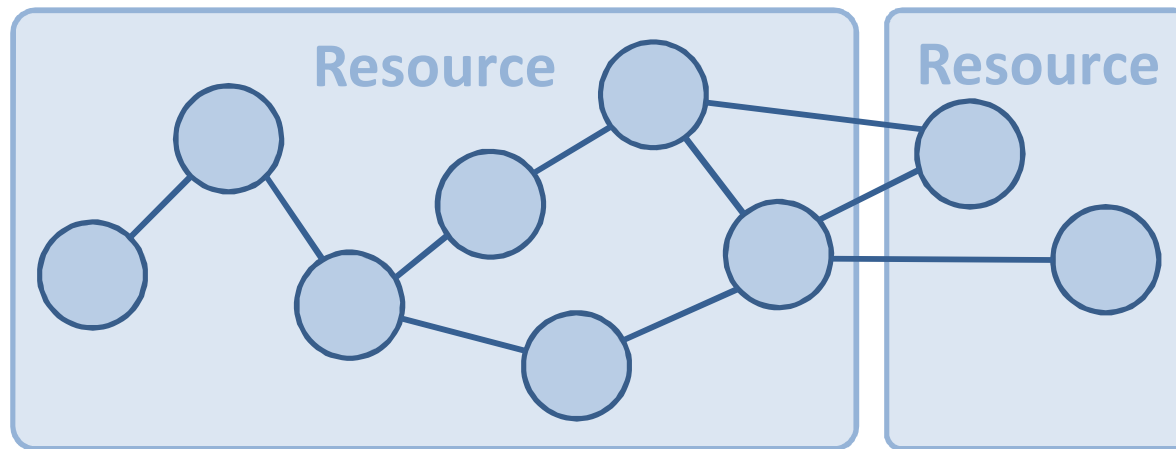

Resource Set

# Issues

- URIs are quite general / need central setup
- No overall dirty state
- No commit / rollback (ACID)
- No lifecycle / missing dispose()

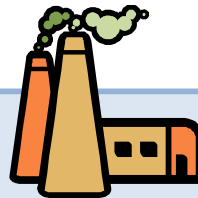

Resource Set



# Data Volumes

Type	Instances
Classifications	12
Products	88
Components	470
Versions	1079
Myzillas	27259
Comments	35799
<b>Total Objects</b>	<b>64707</b>

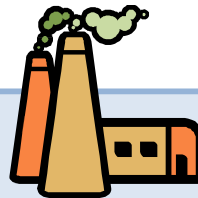

Resource Set

# User Interface

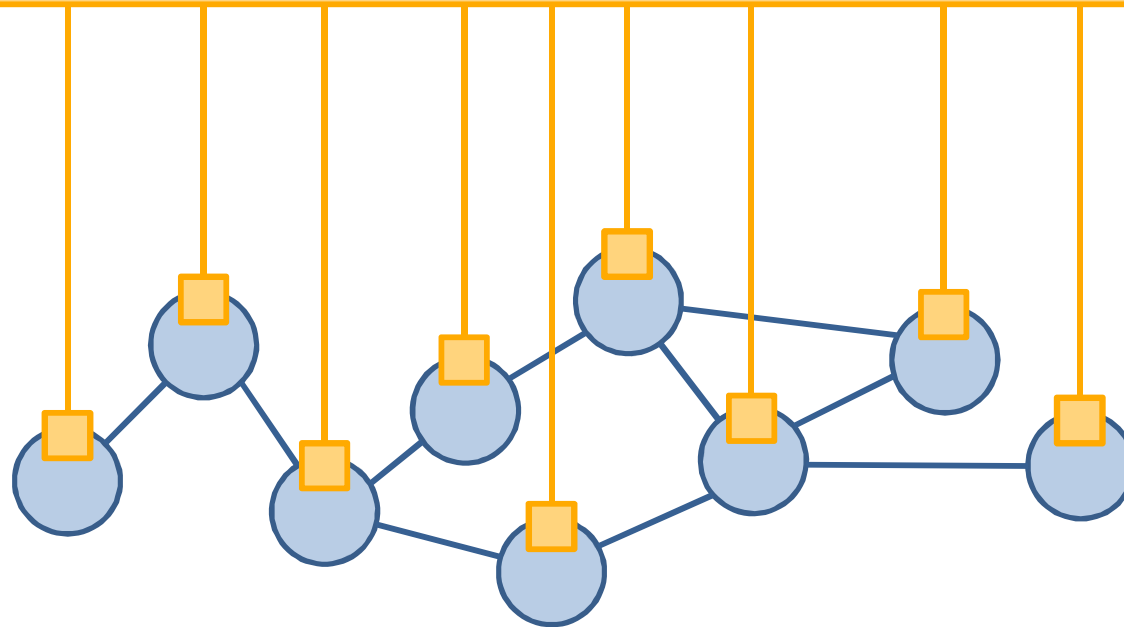

# Storage Layer

# User Interface

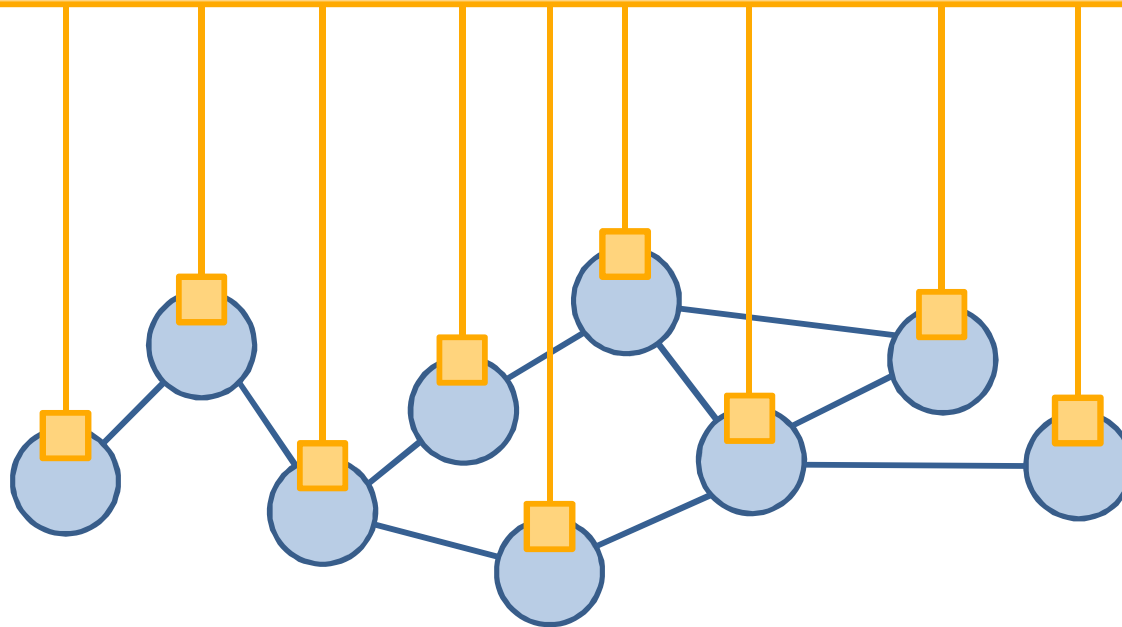

# Storage Layer

# User Interface

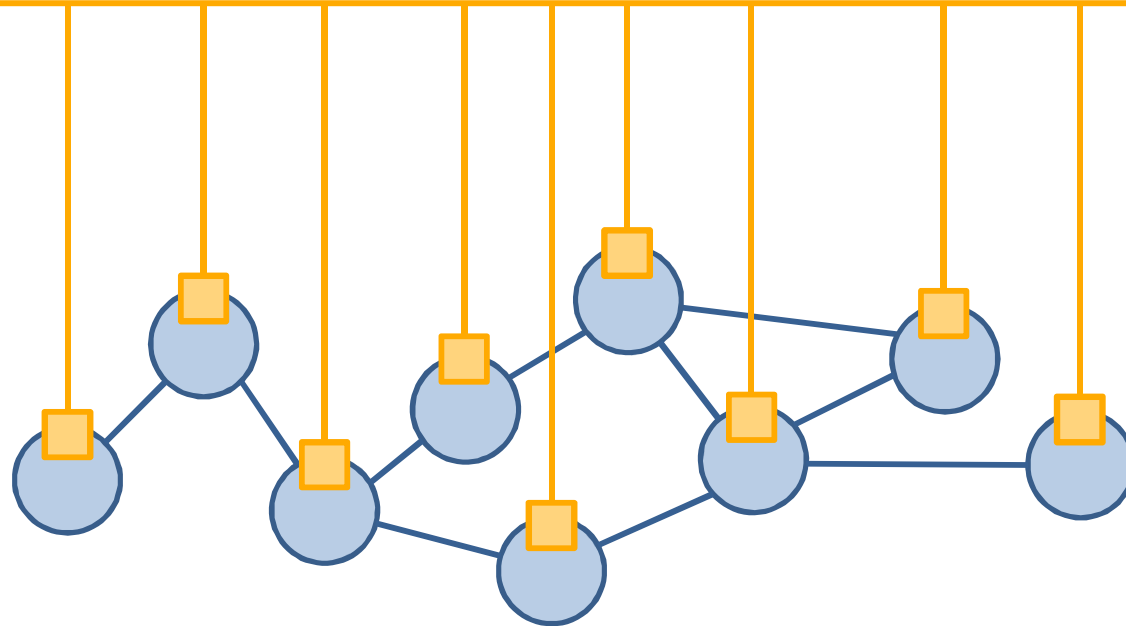

# Storage Layer

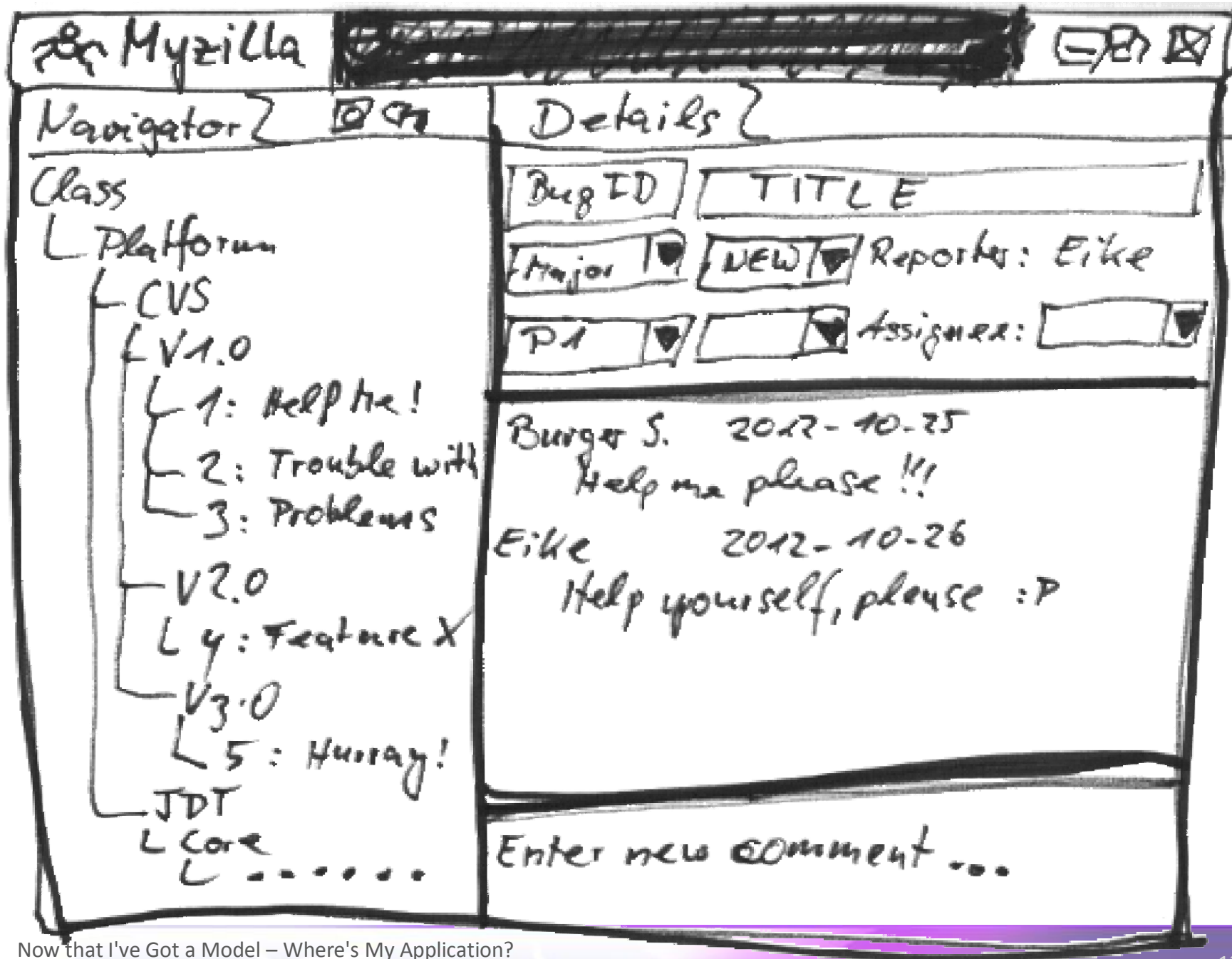

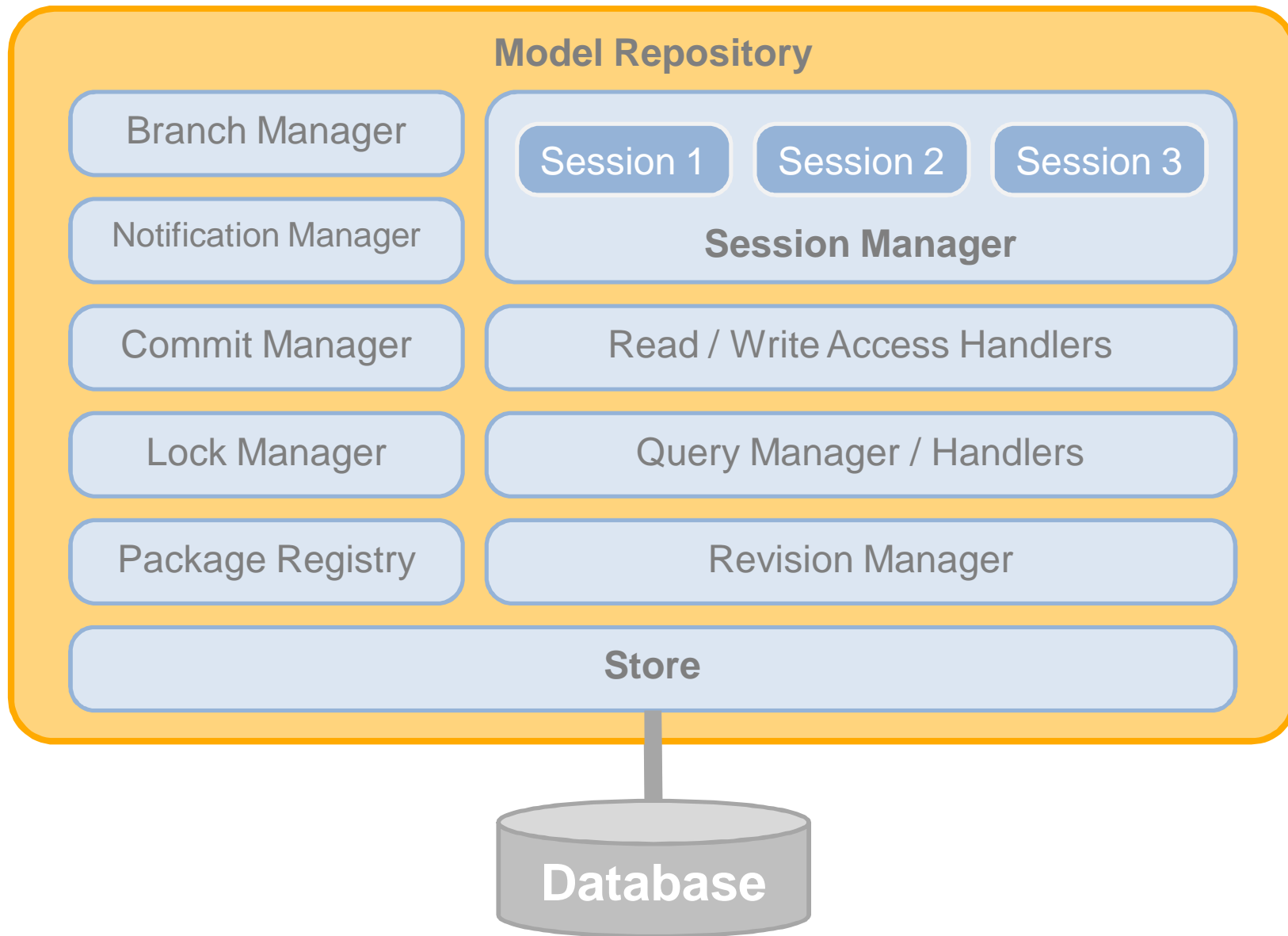

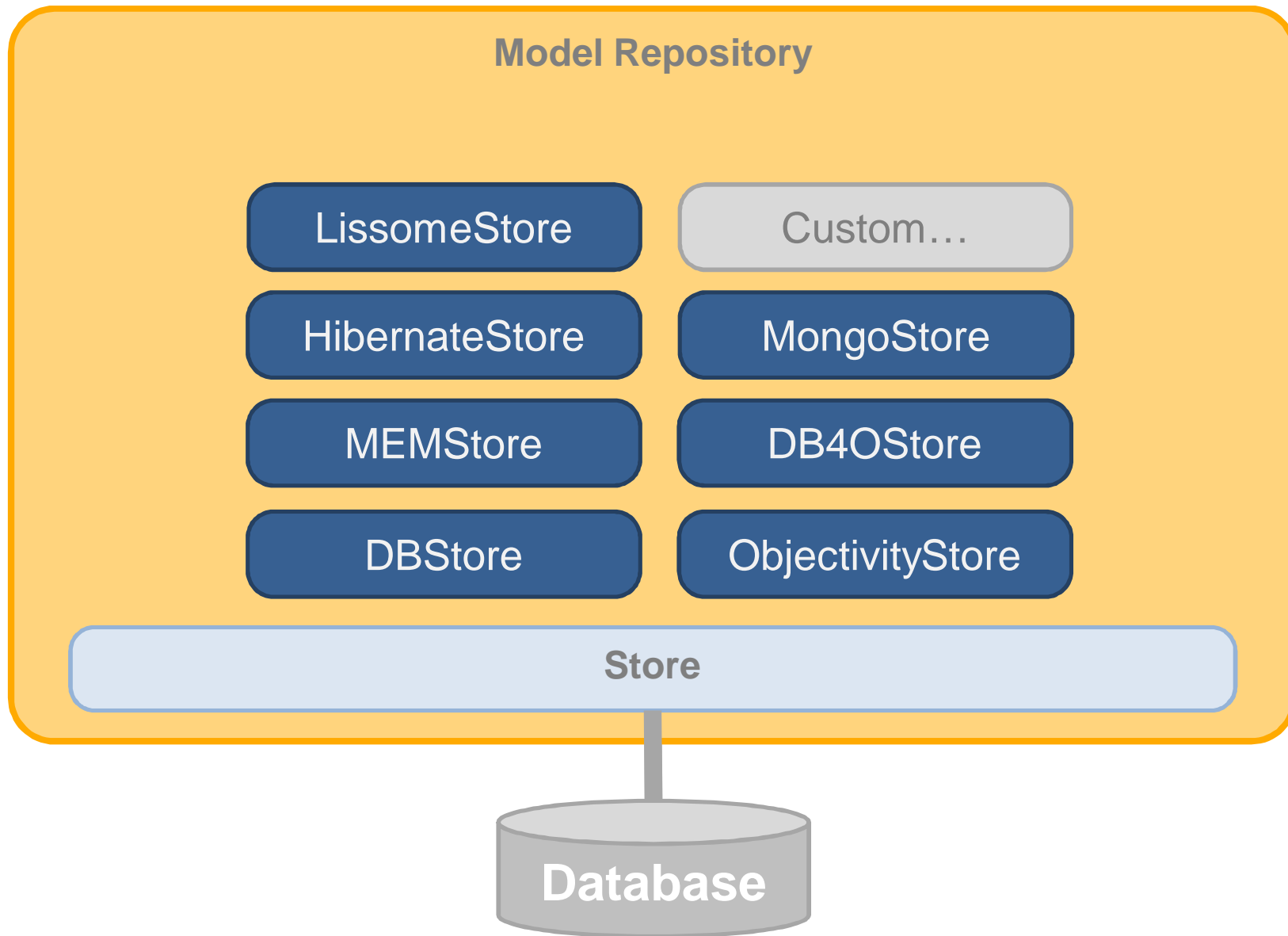

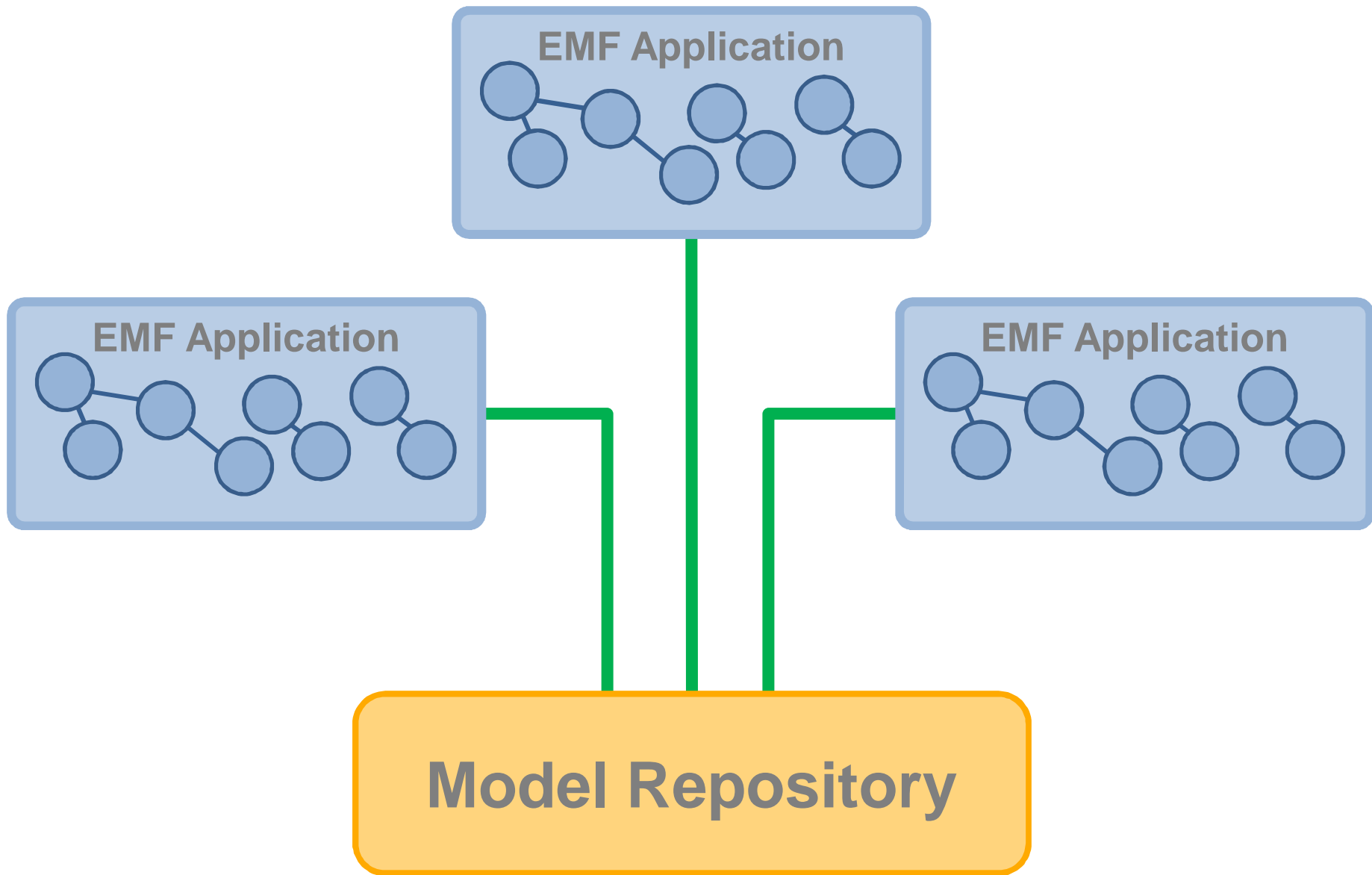



## Modify

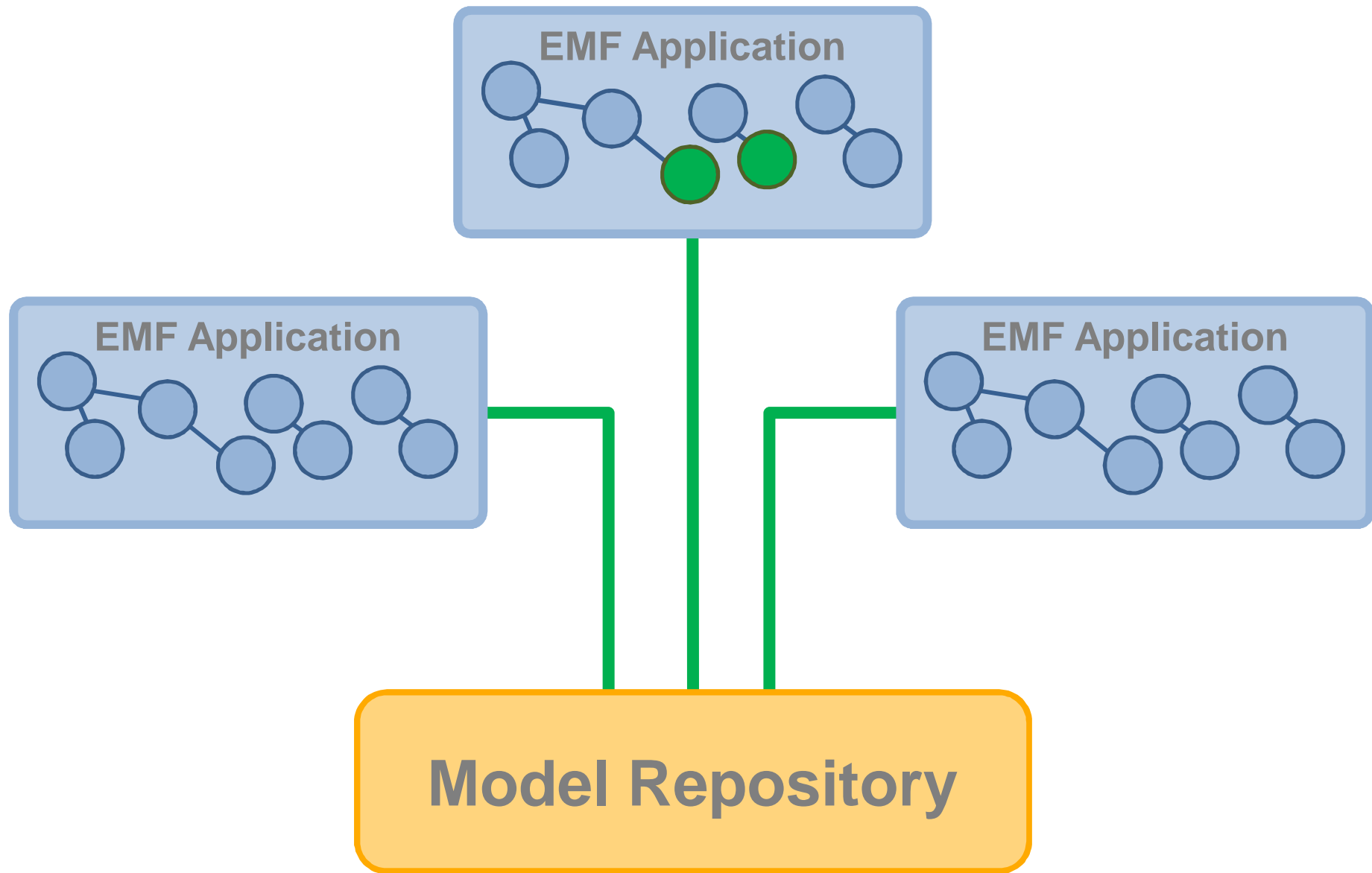

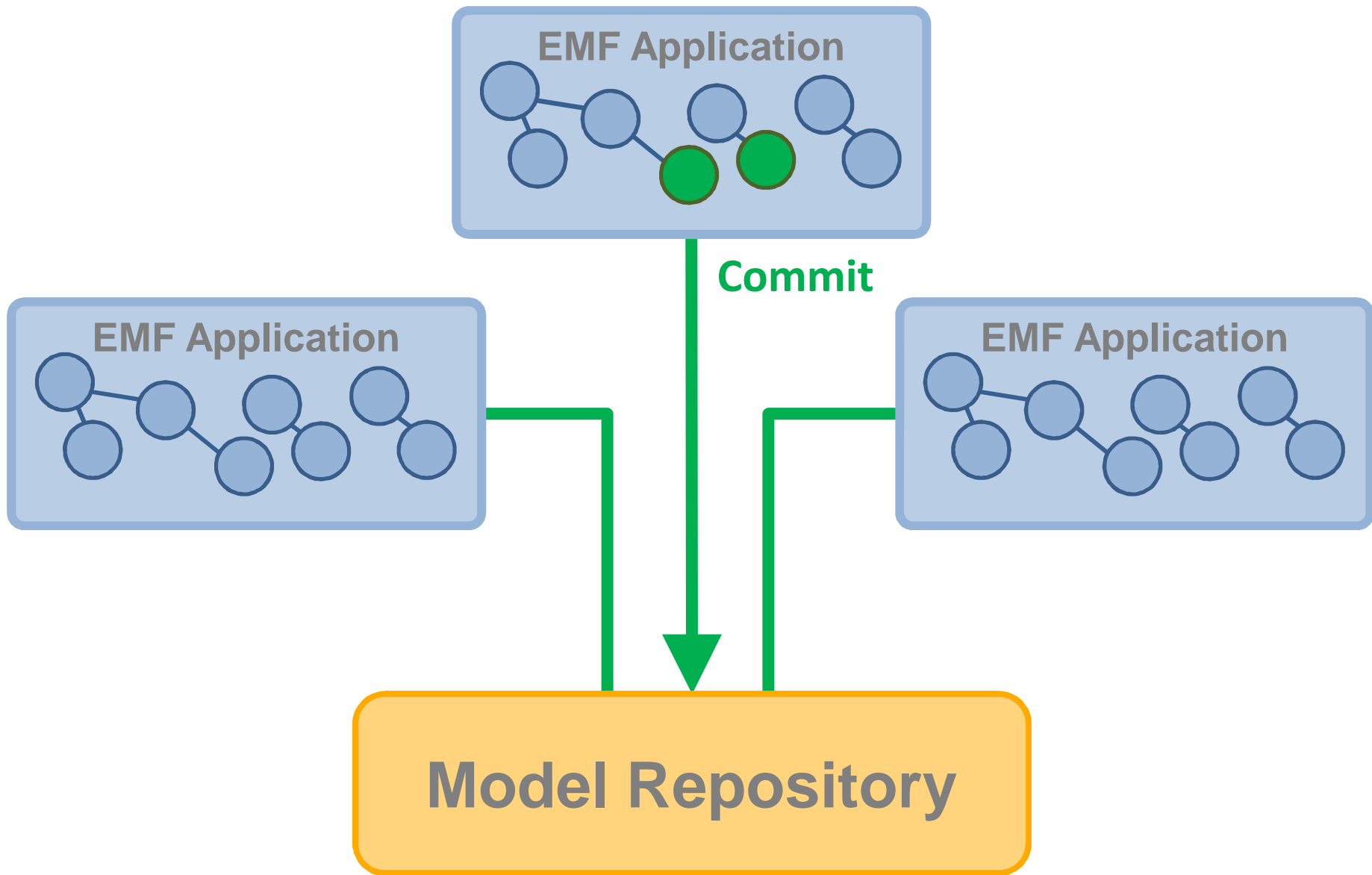

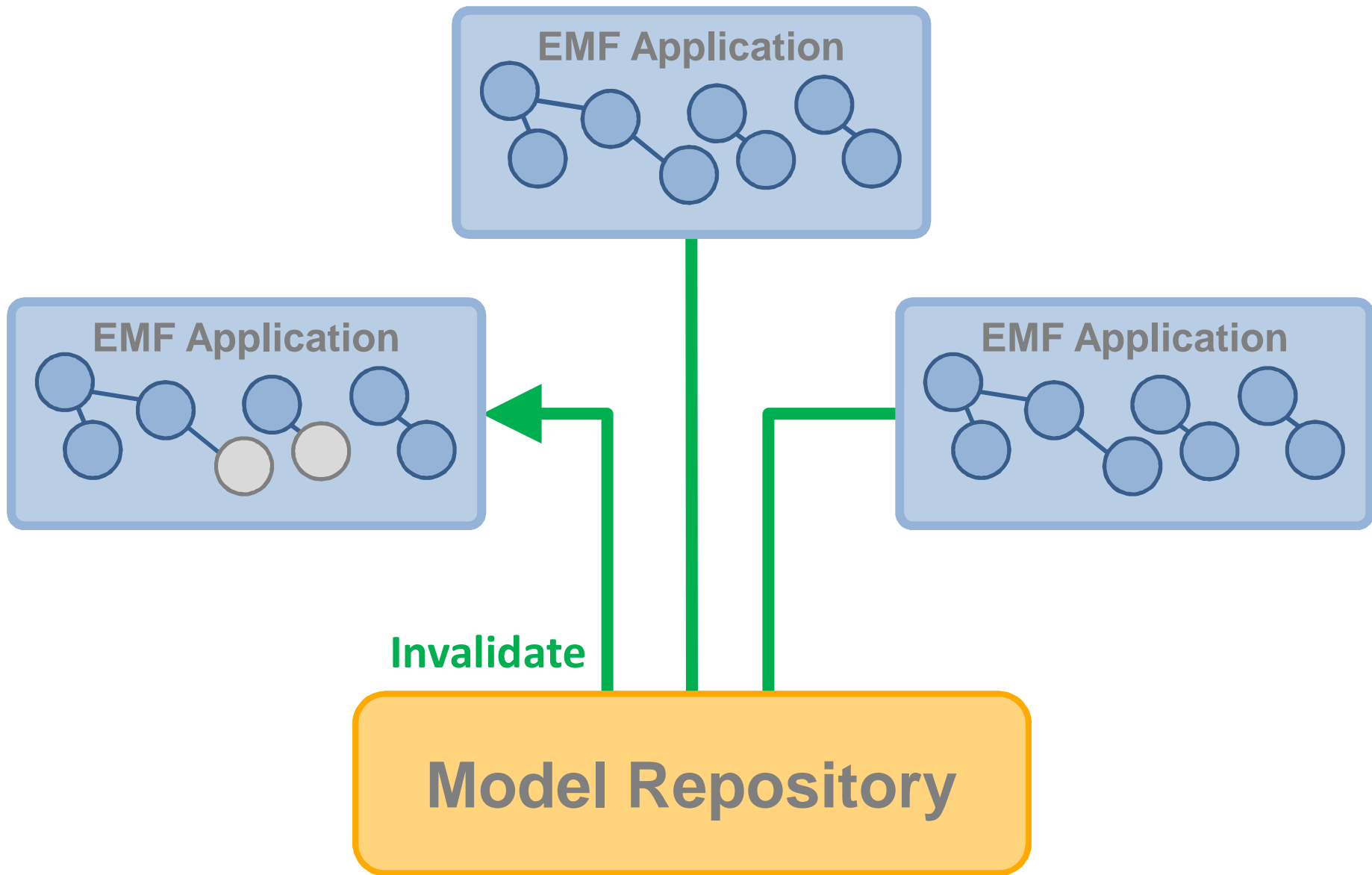

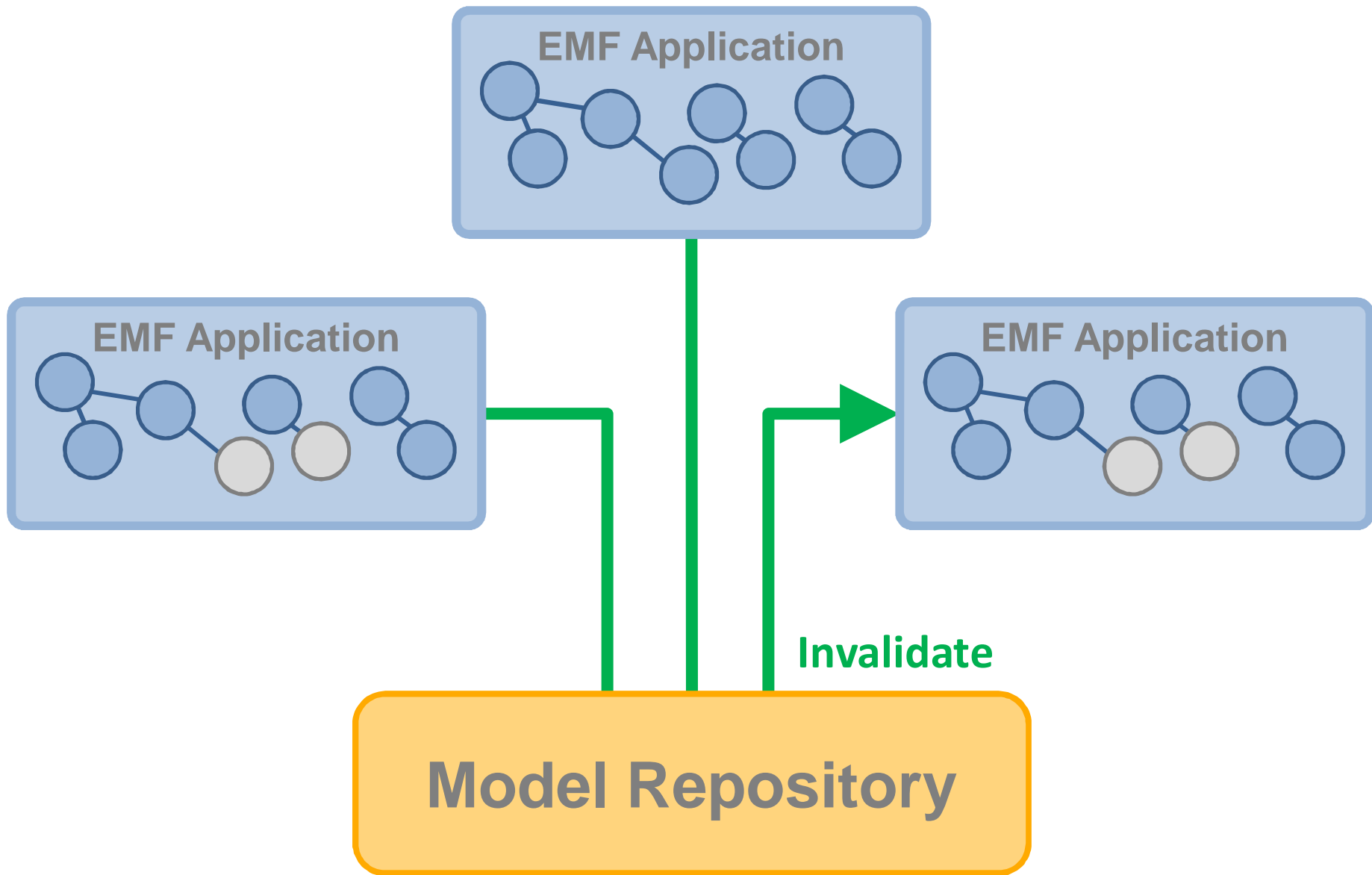

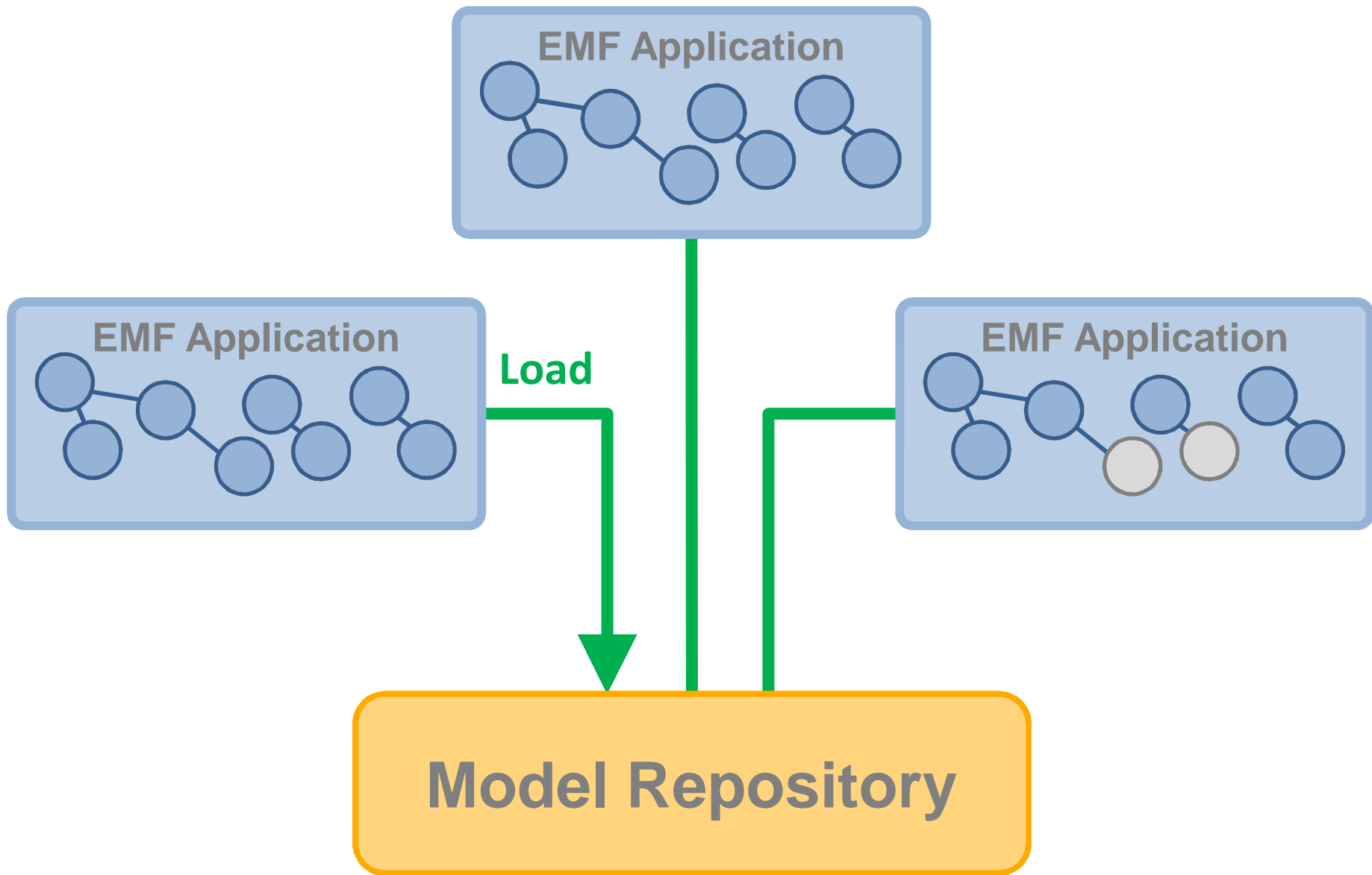

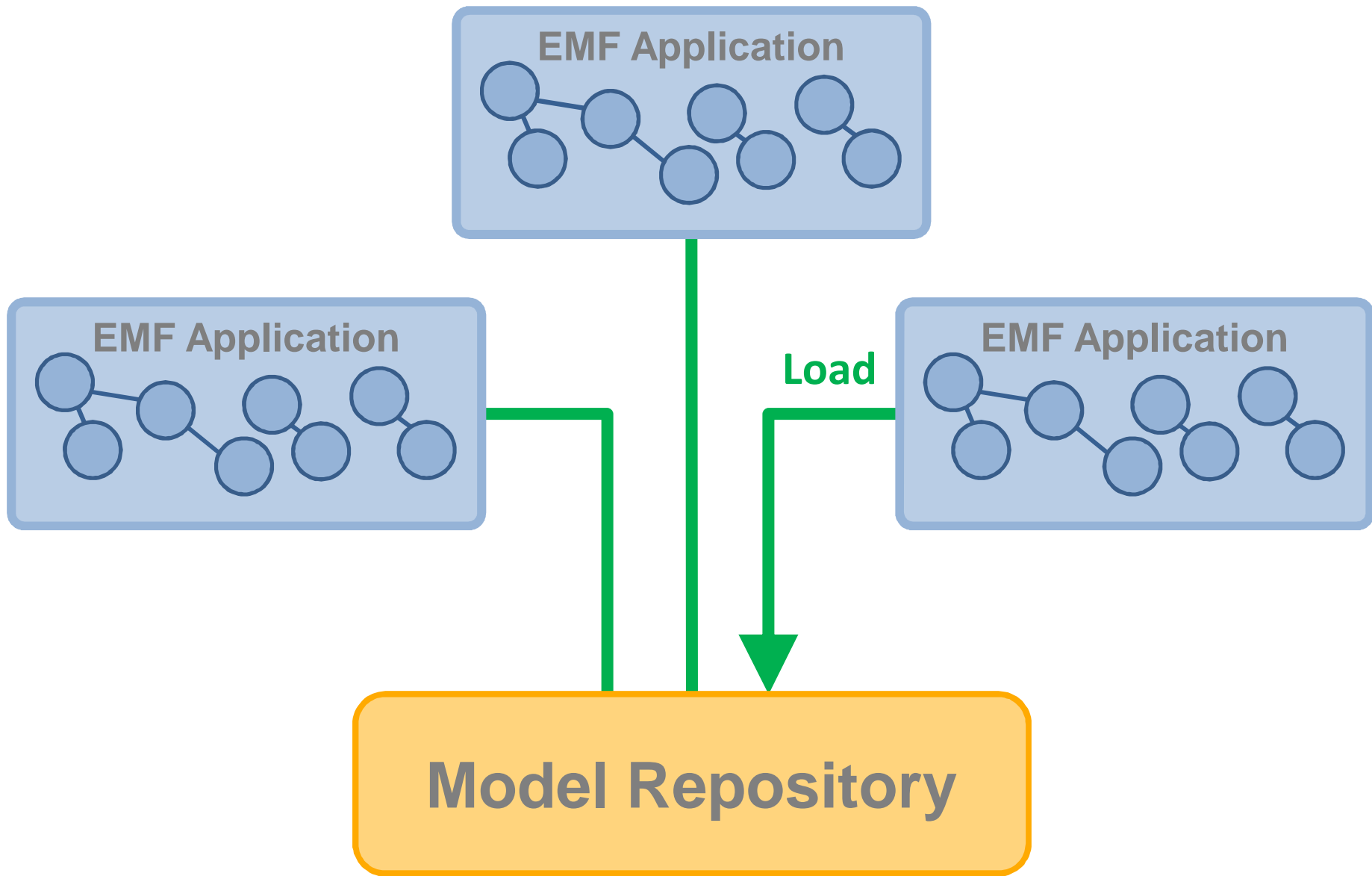

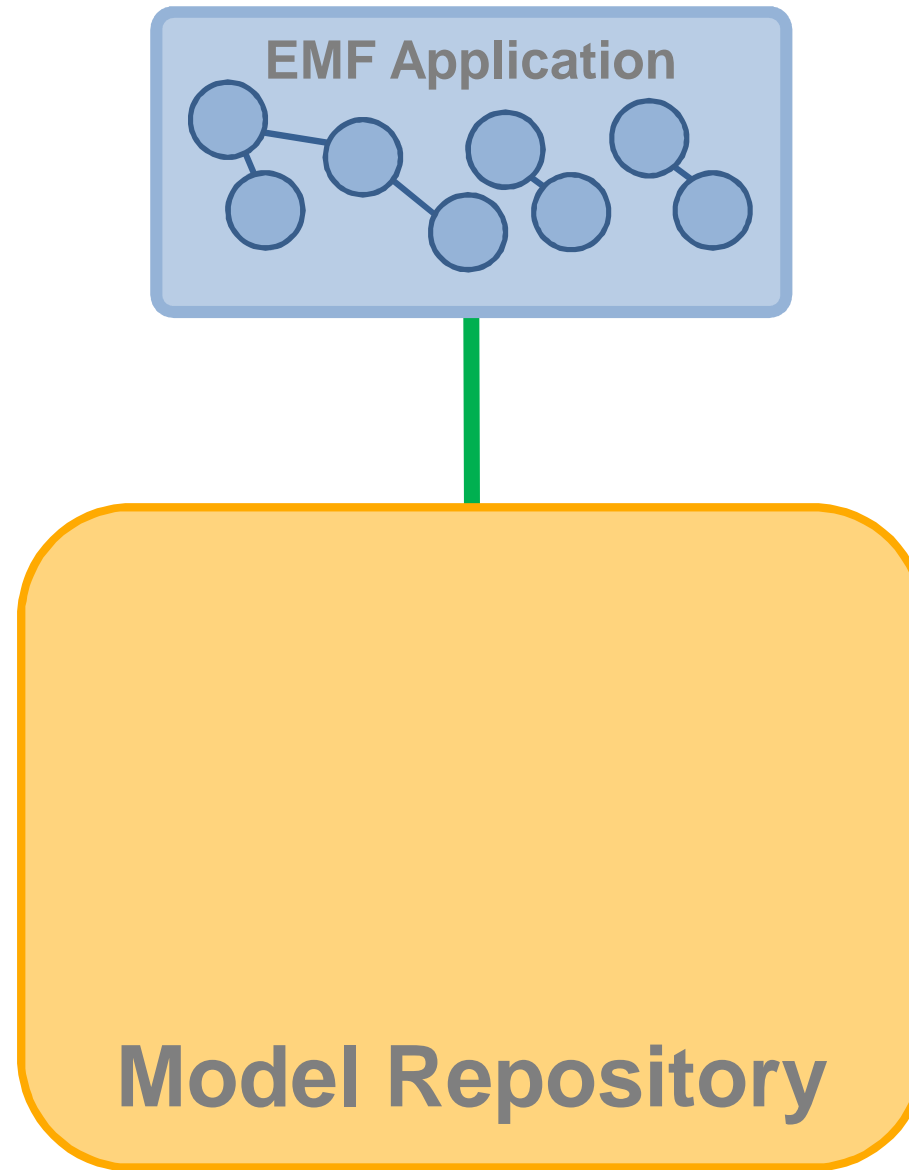

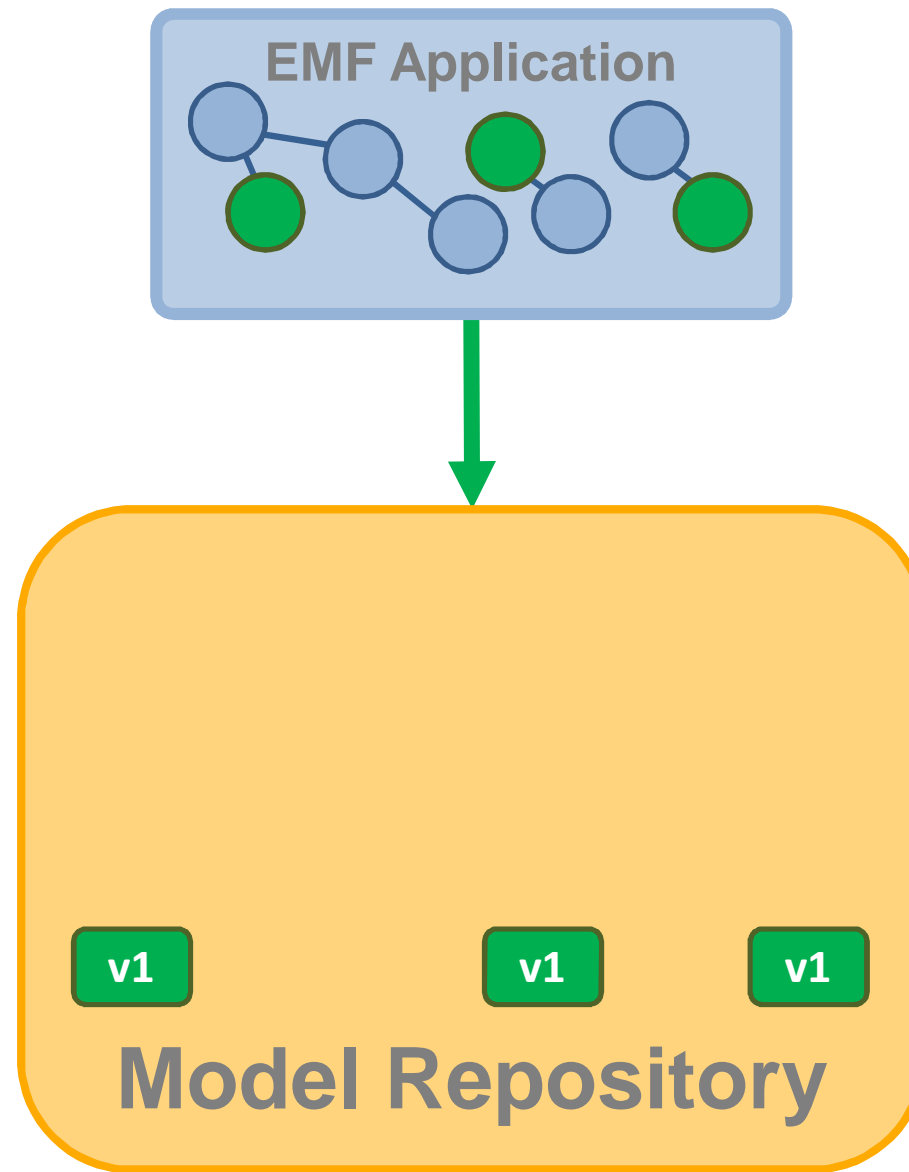



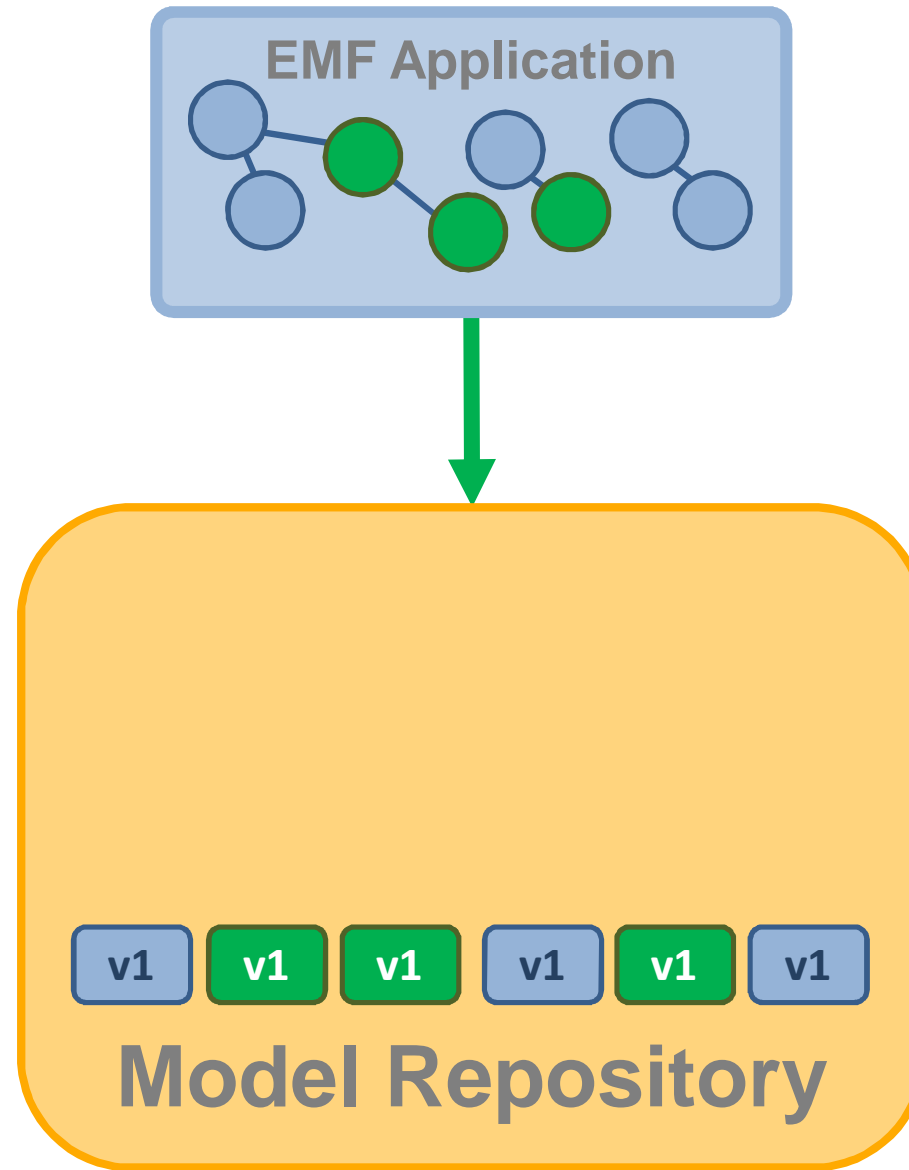

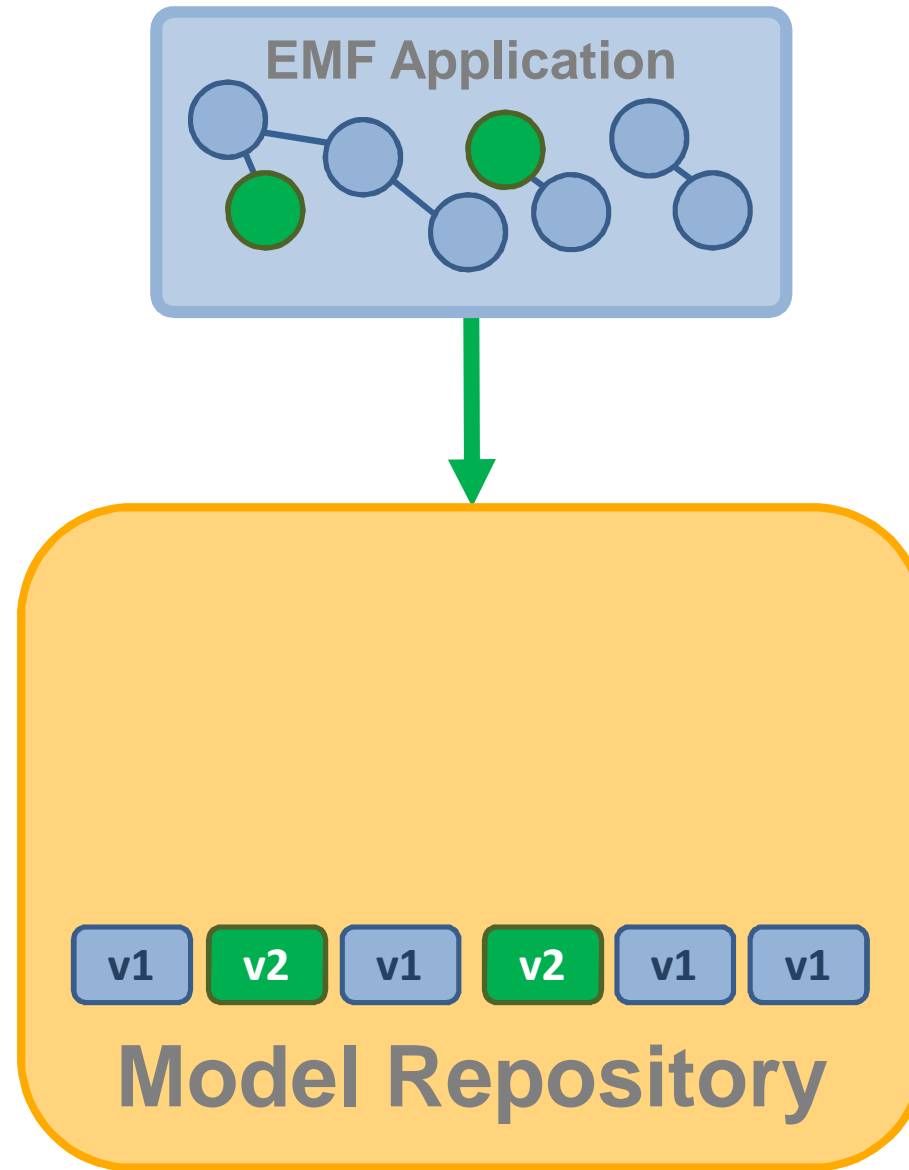

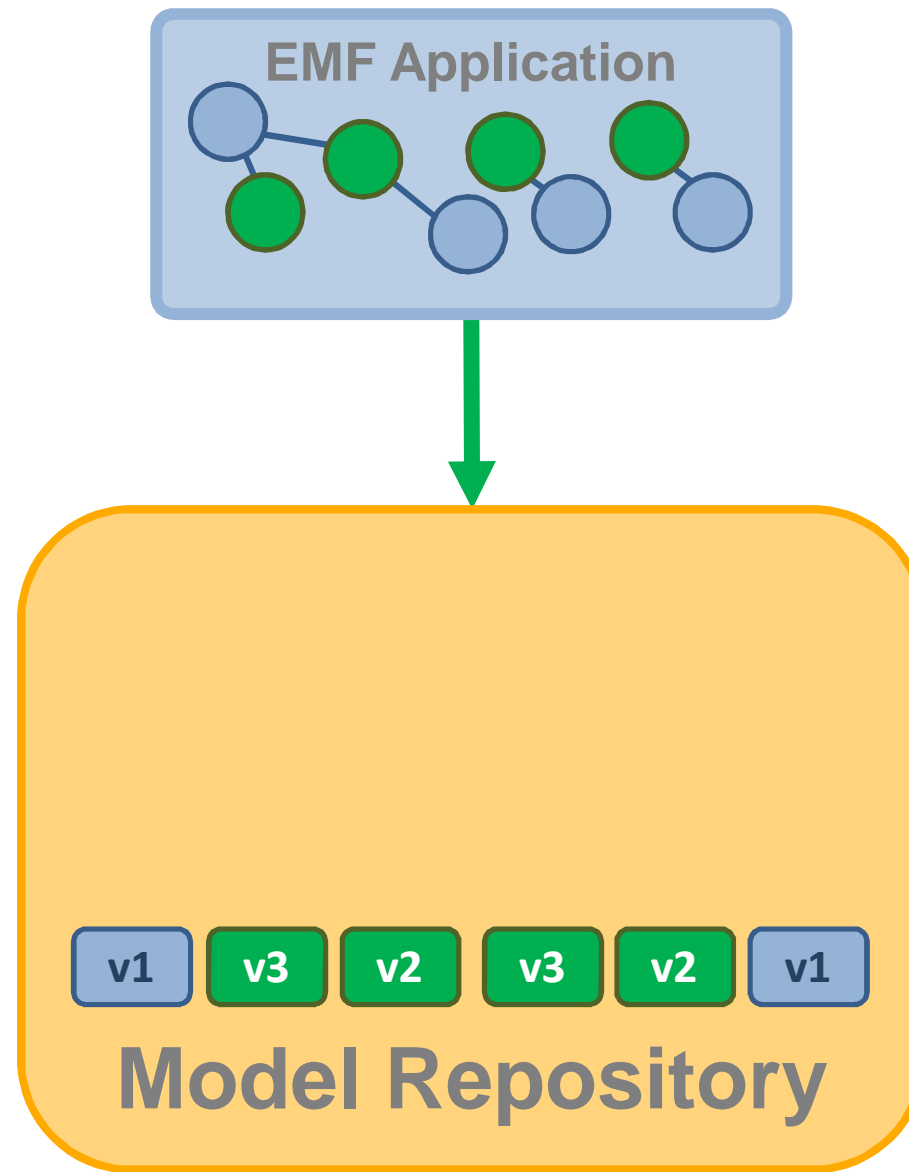

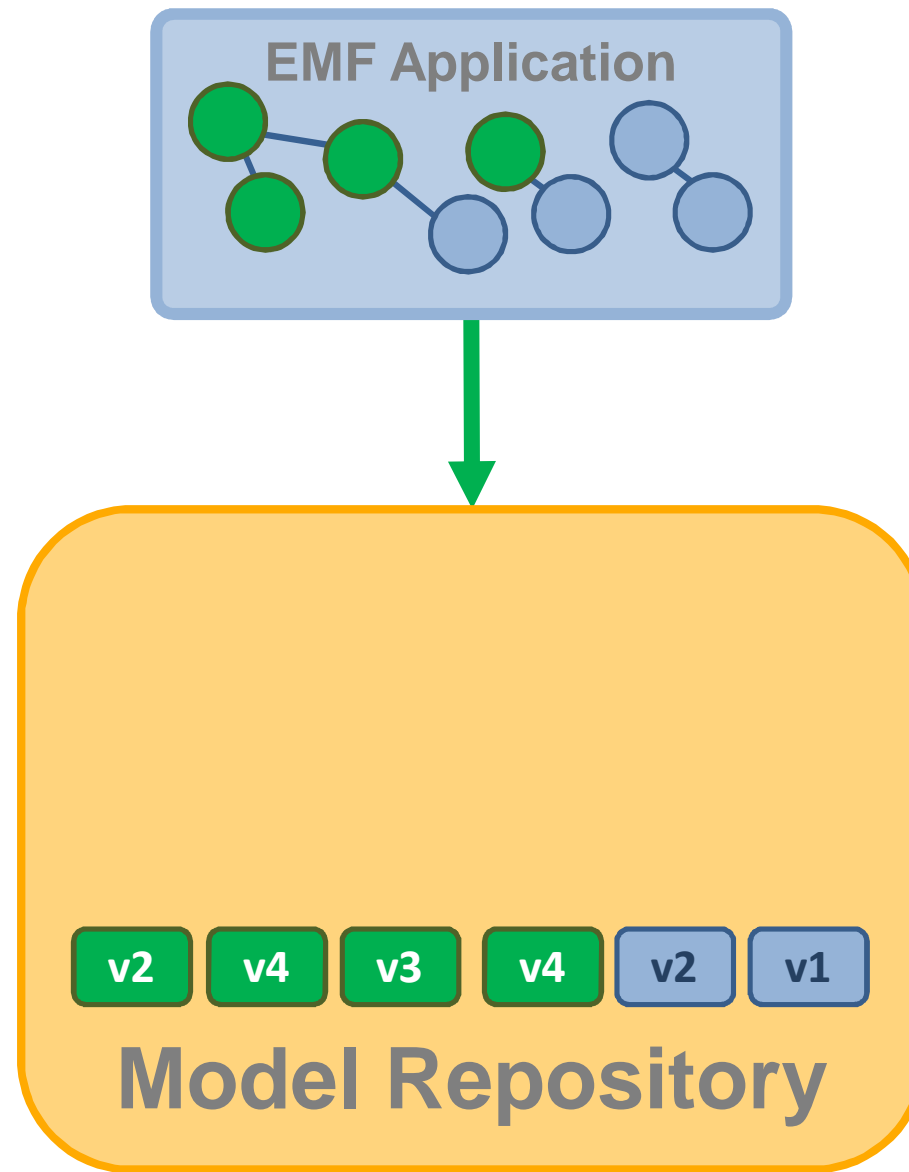

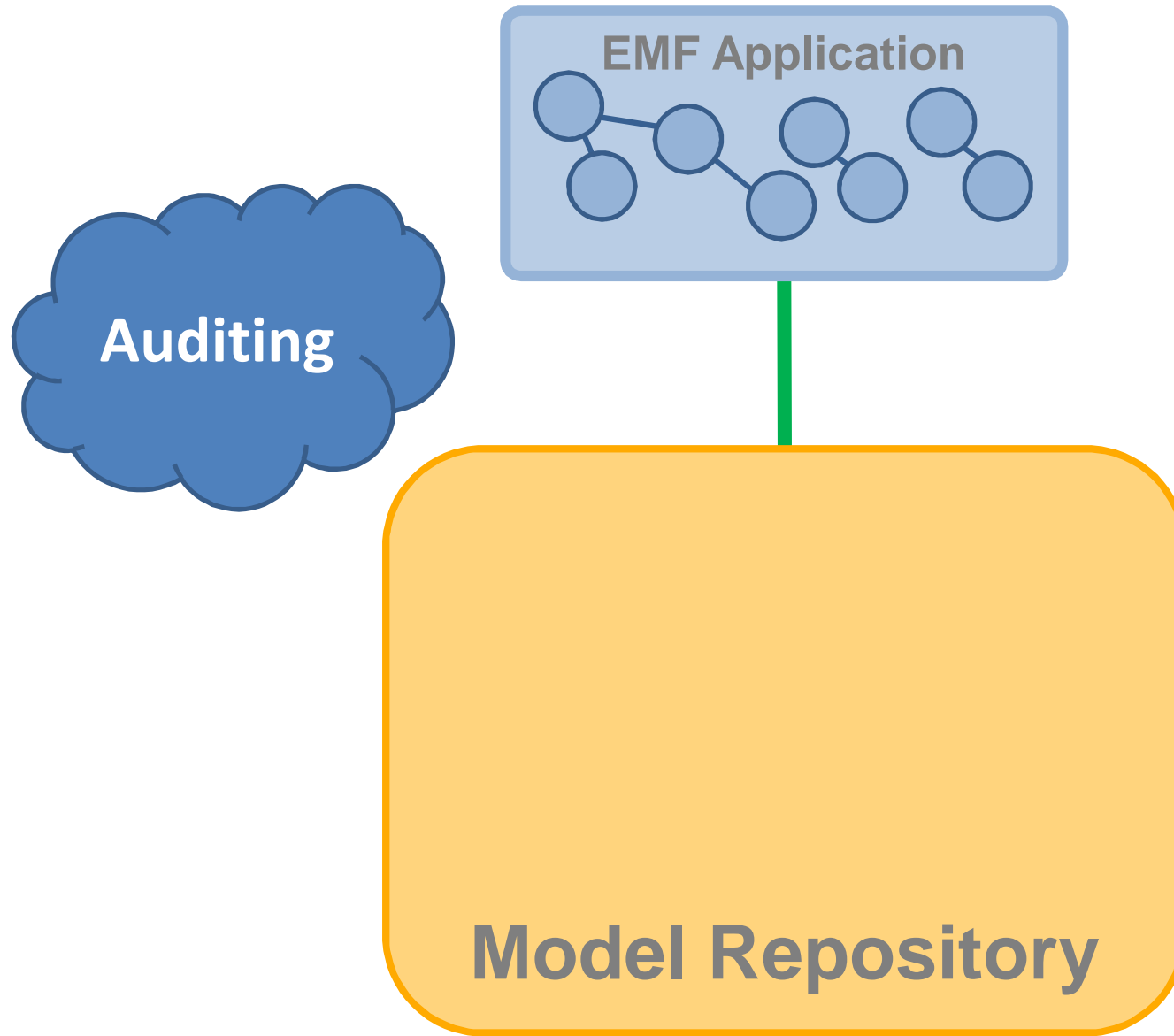

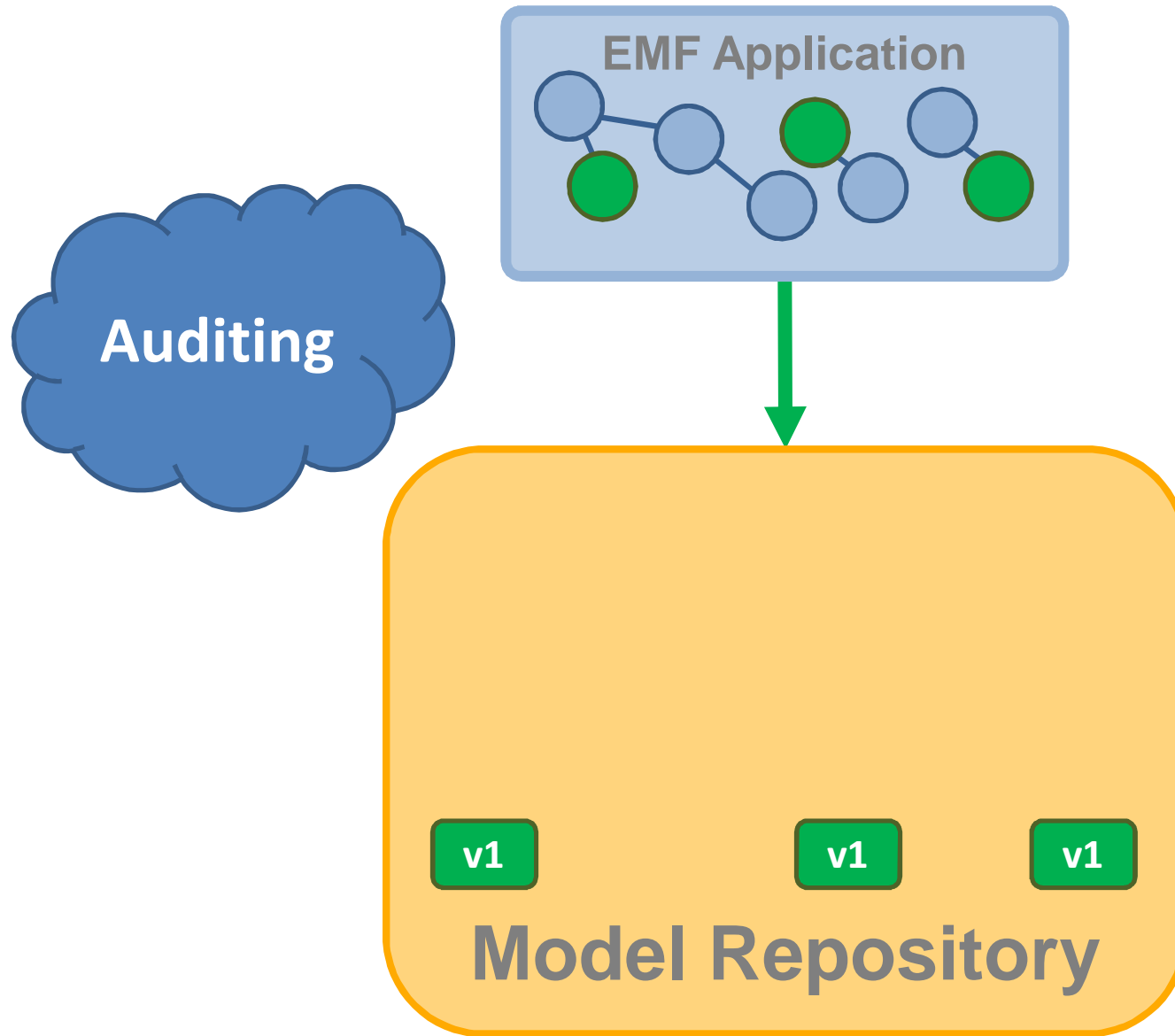

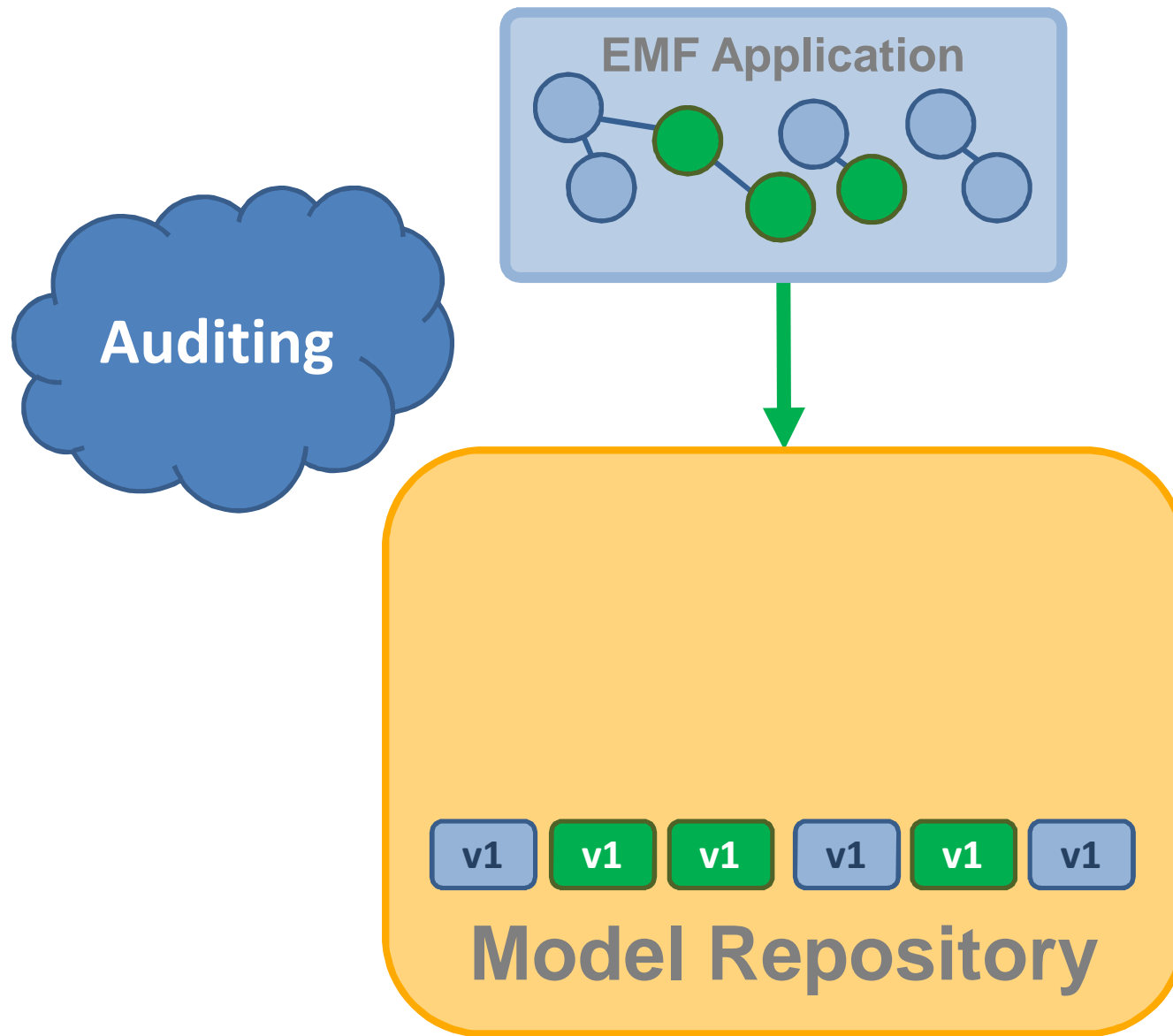

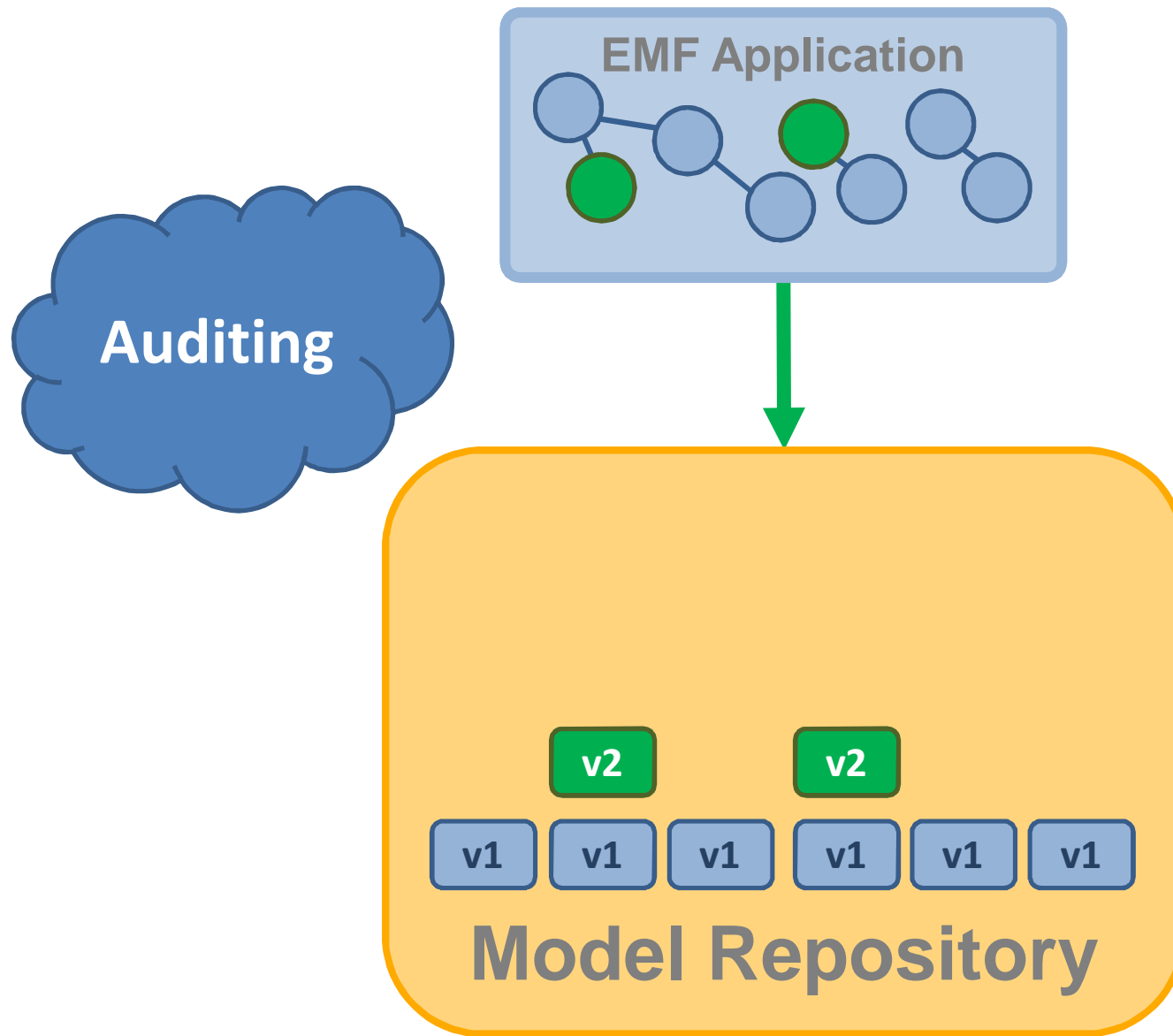



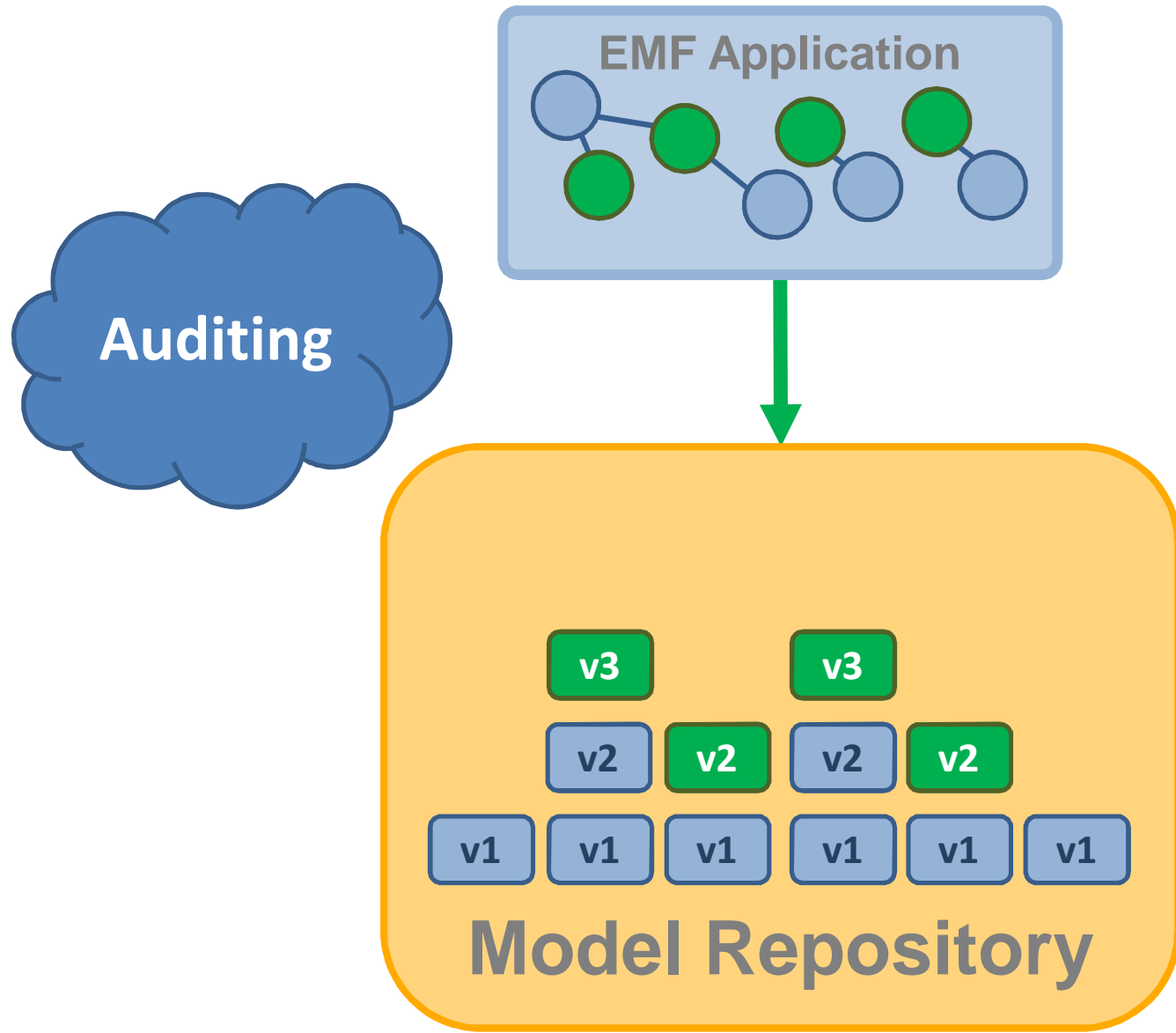

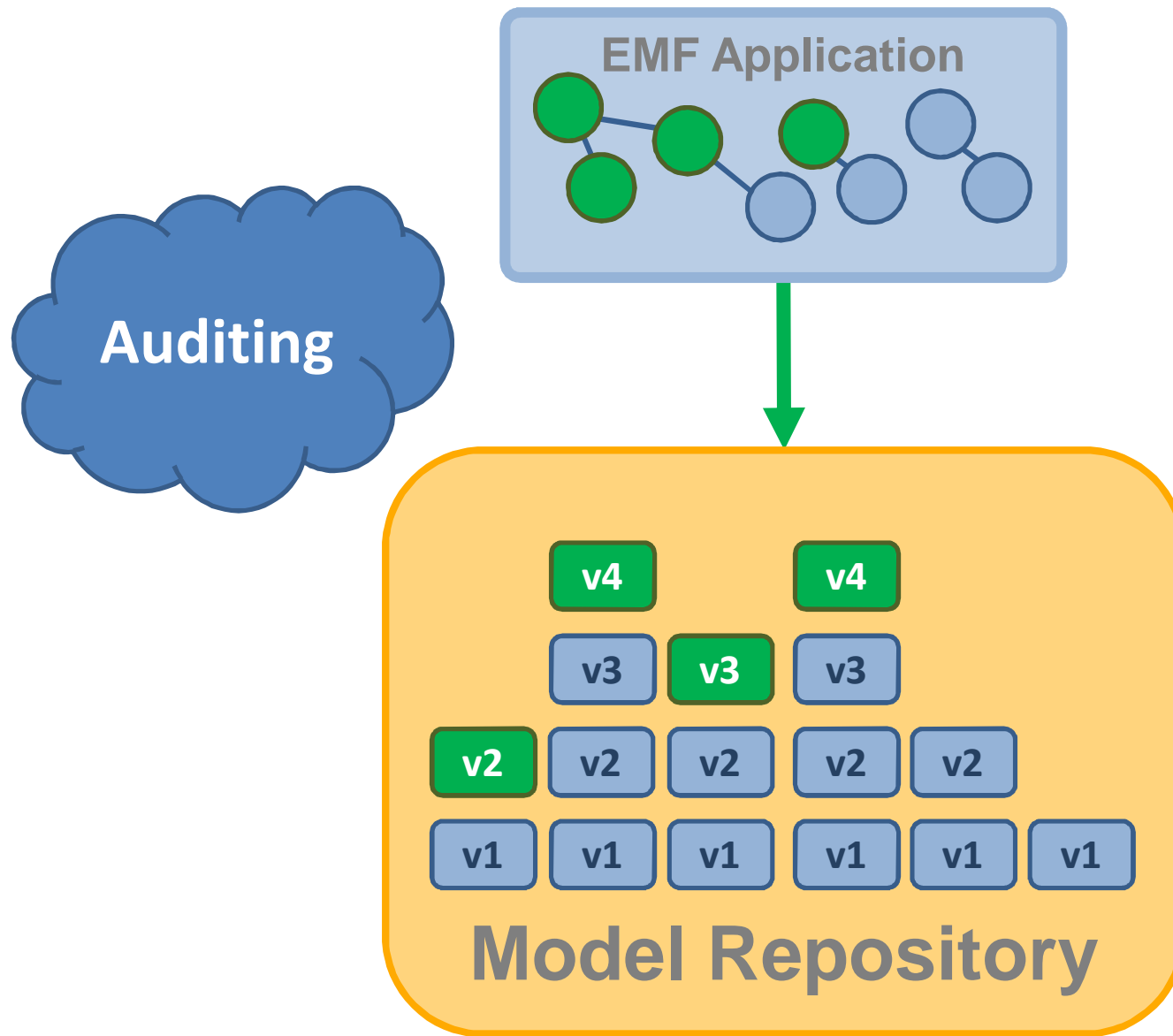

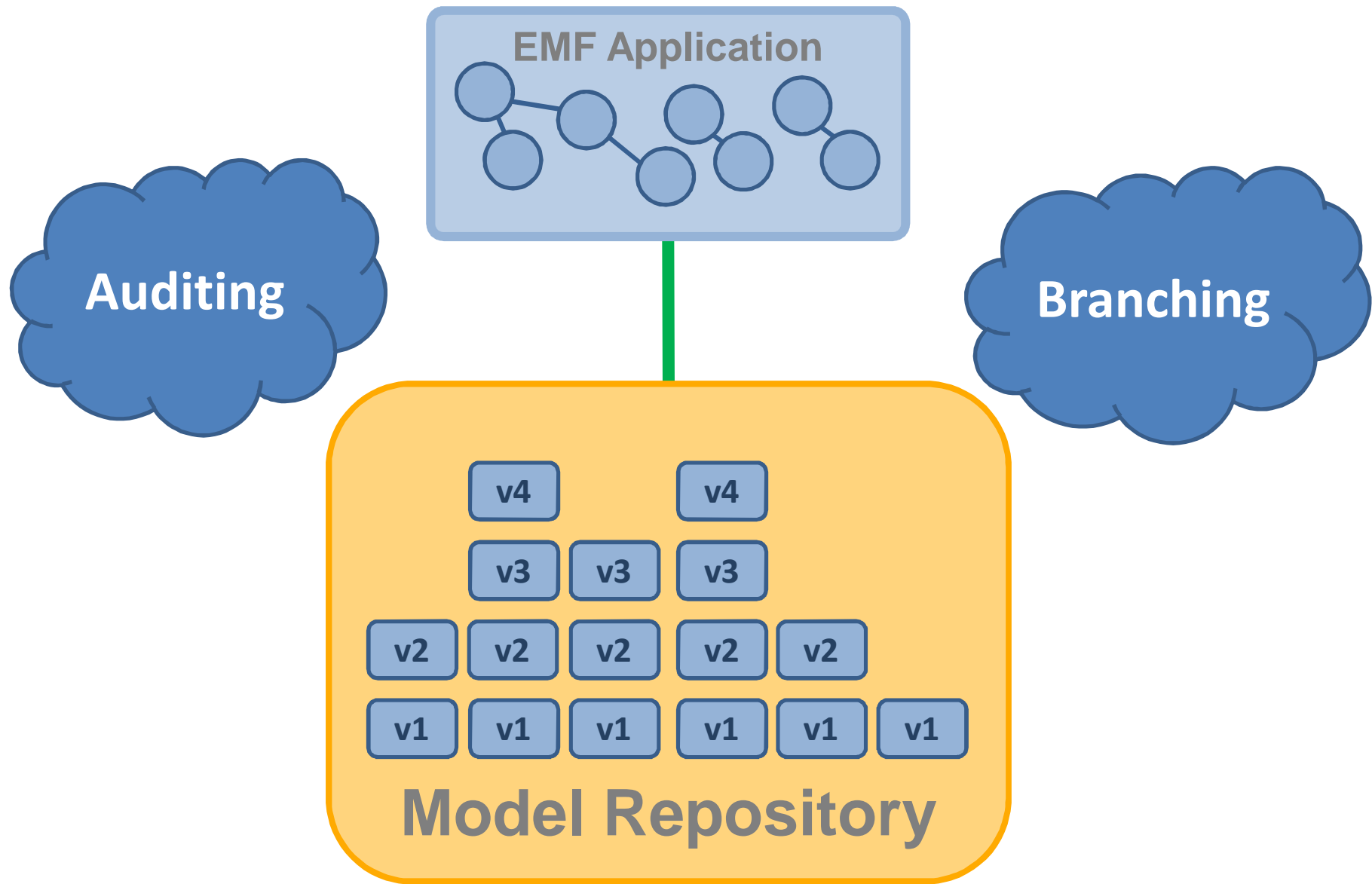

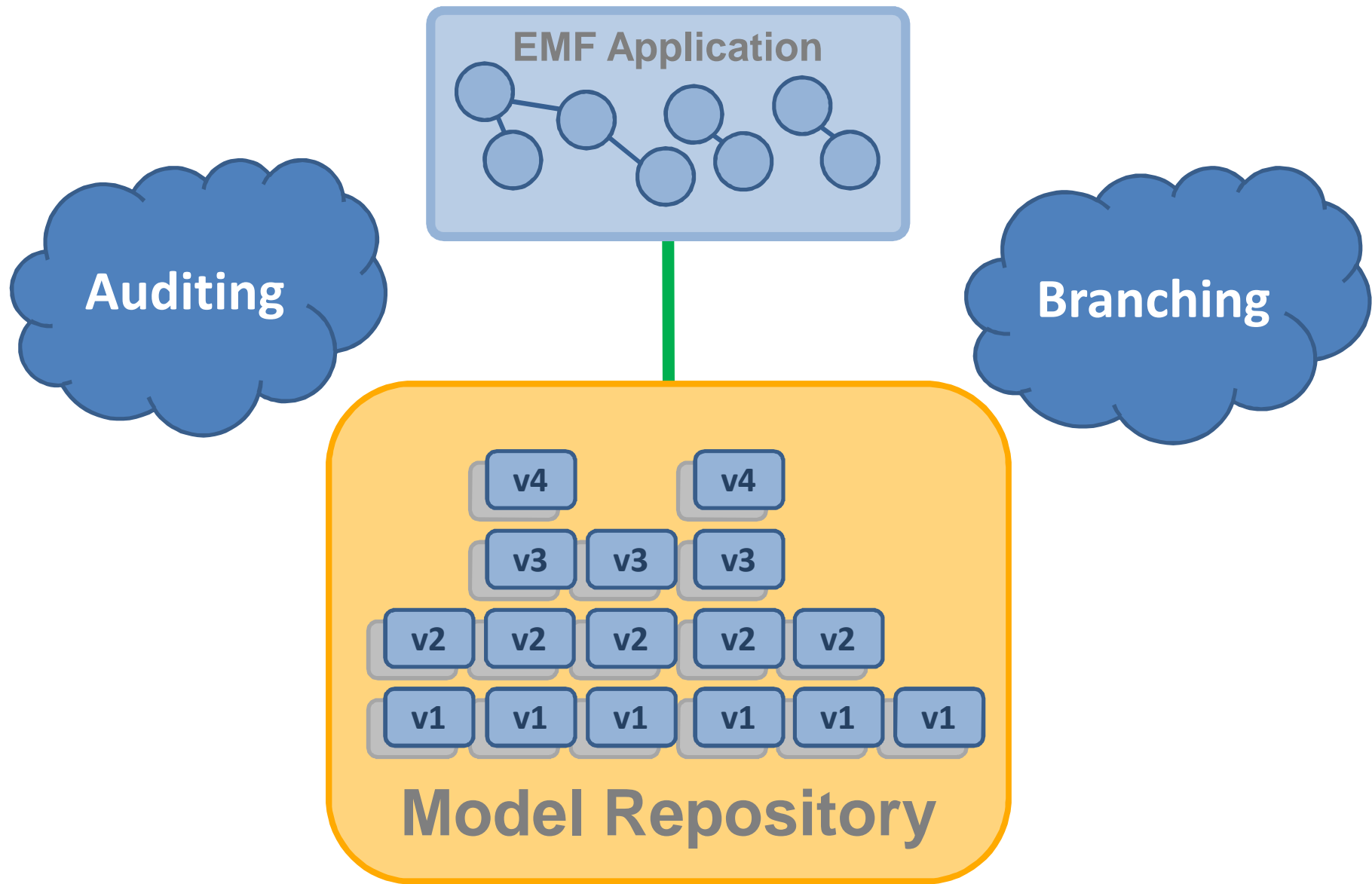

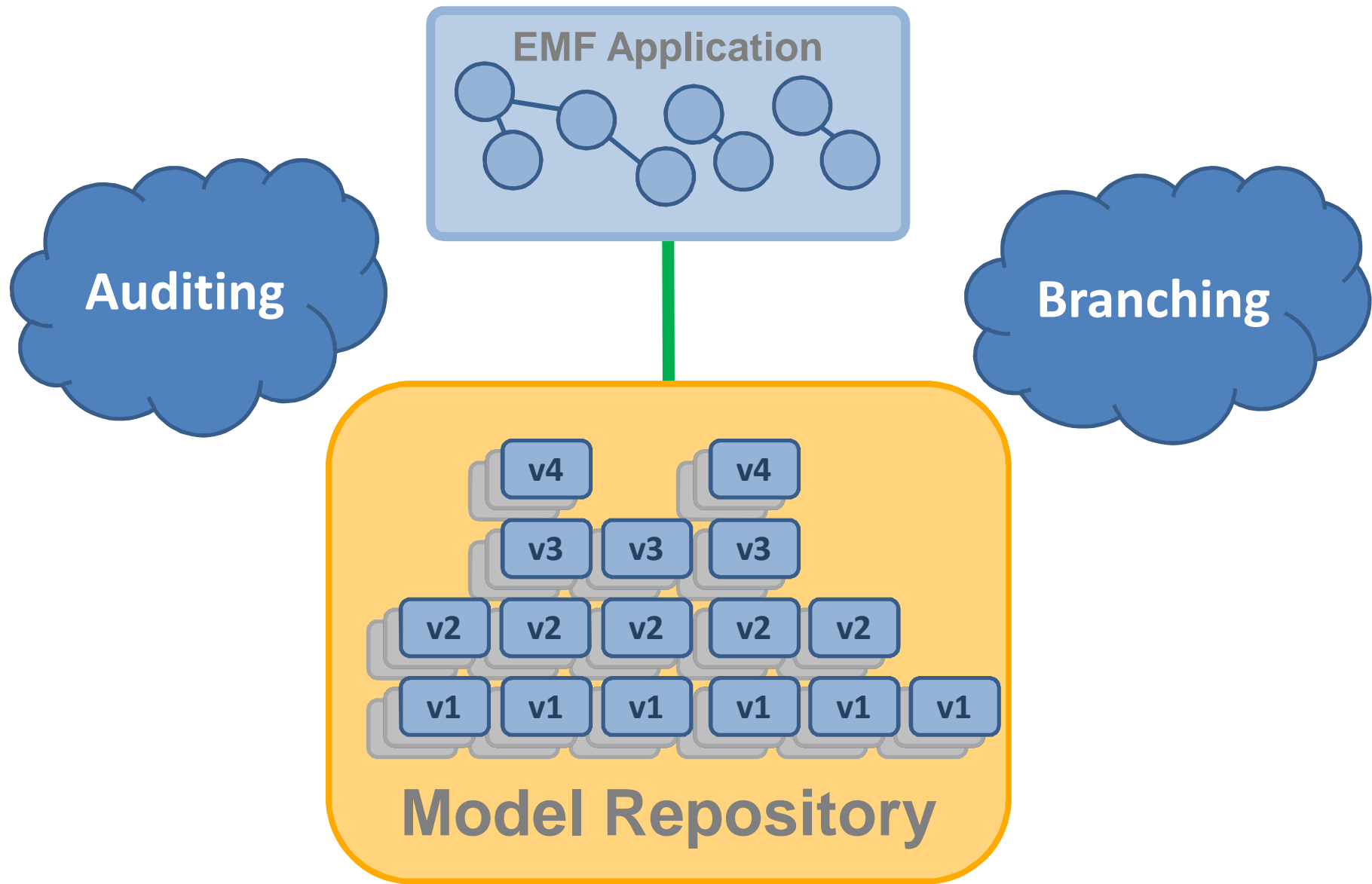

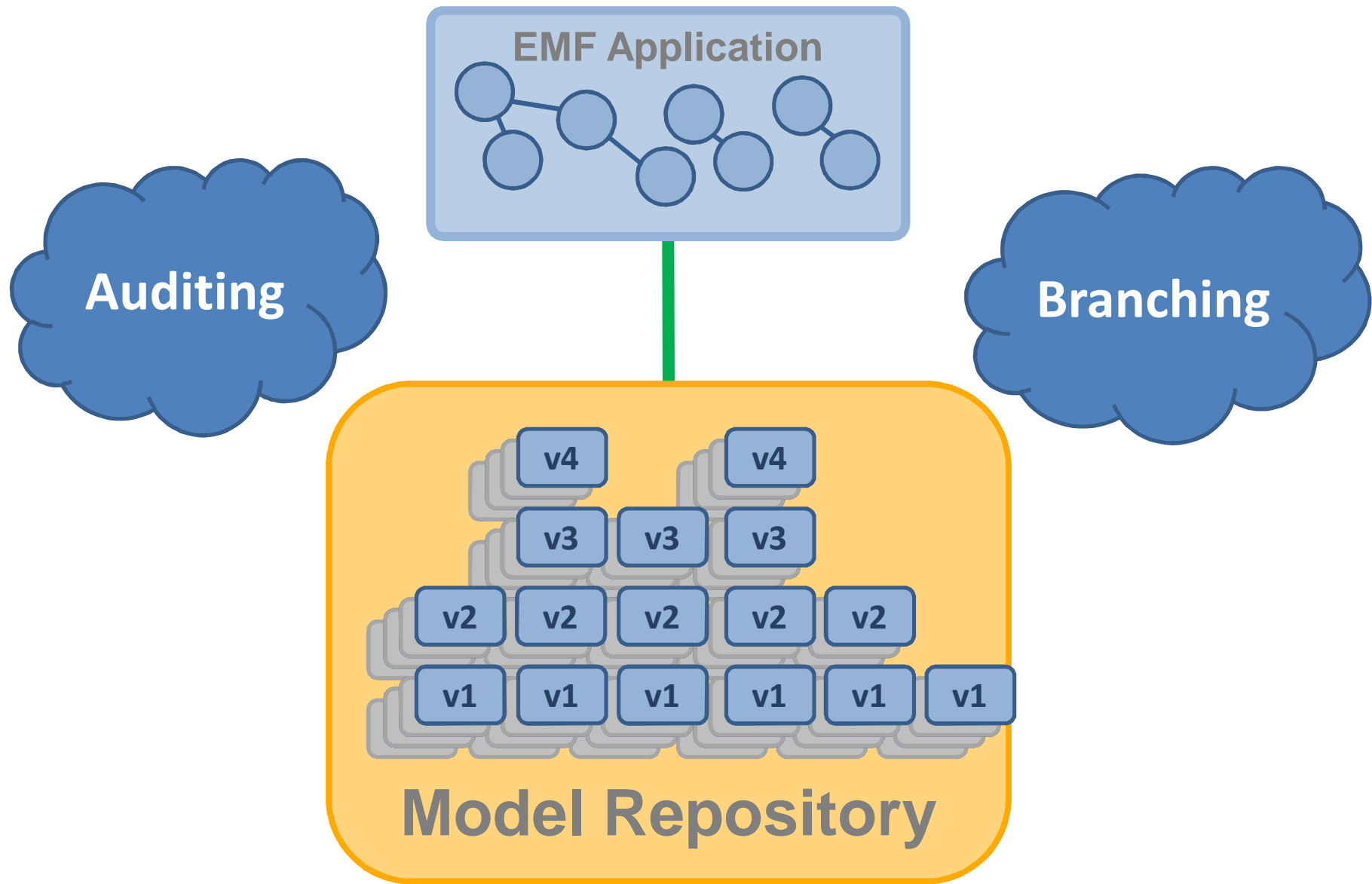

## CDORevision

**EClass eClass**  
**CDOID id**  
**CDOBranch branch**  
**int version**  
**long created**  
**long revised**

### Revision Data

CDOID resourceID  
CDOID containerID  
int containerFeature  
Object[] values



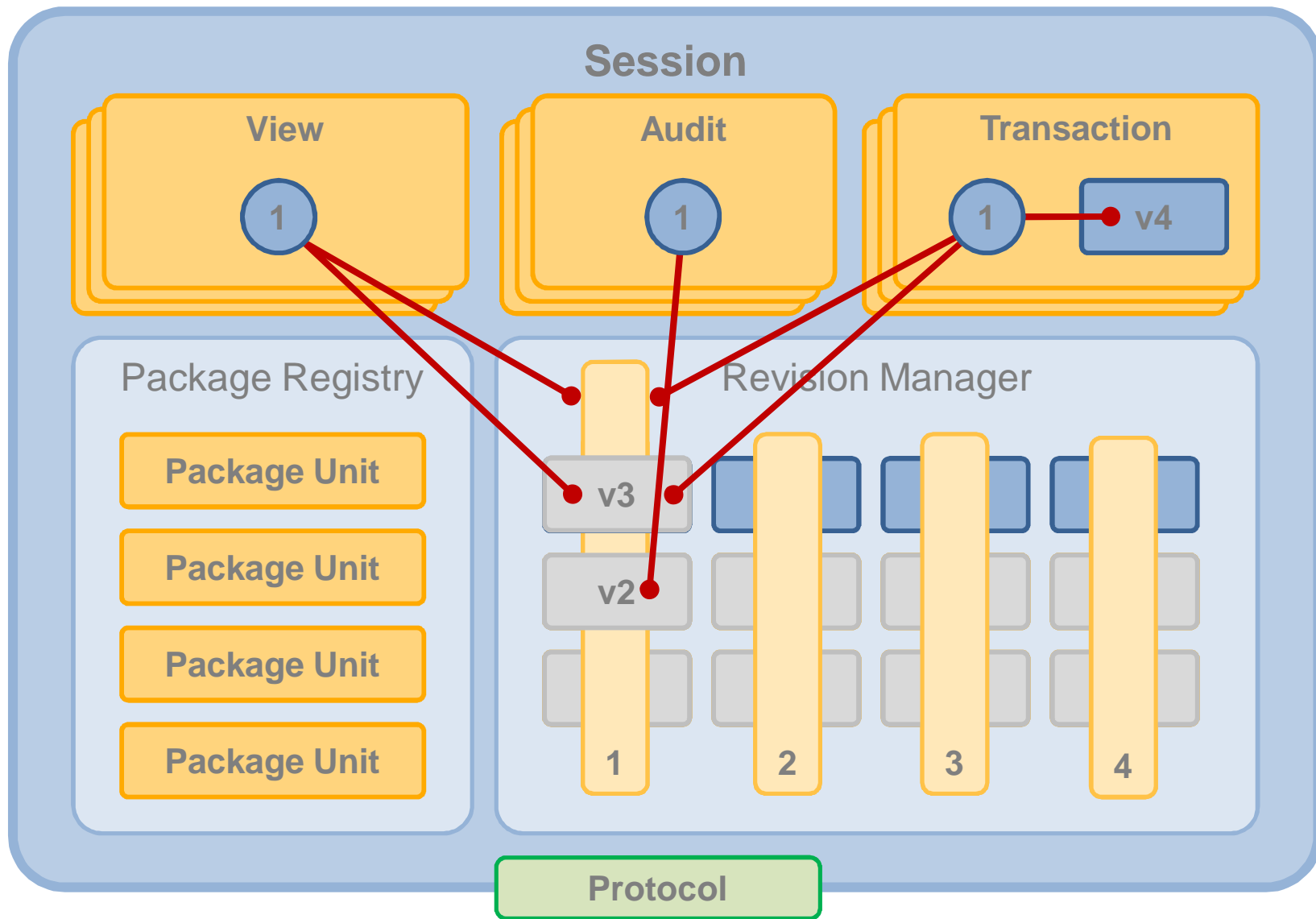



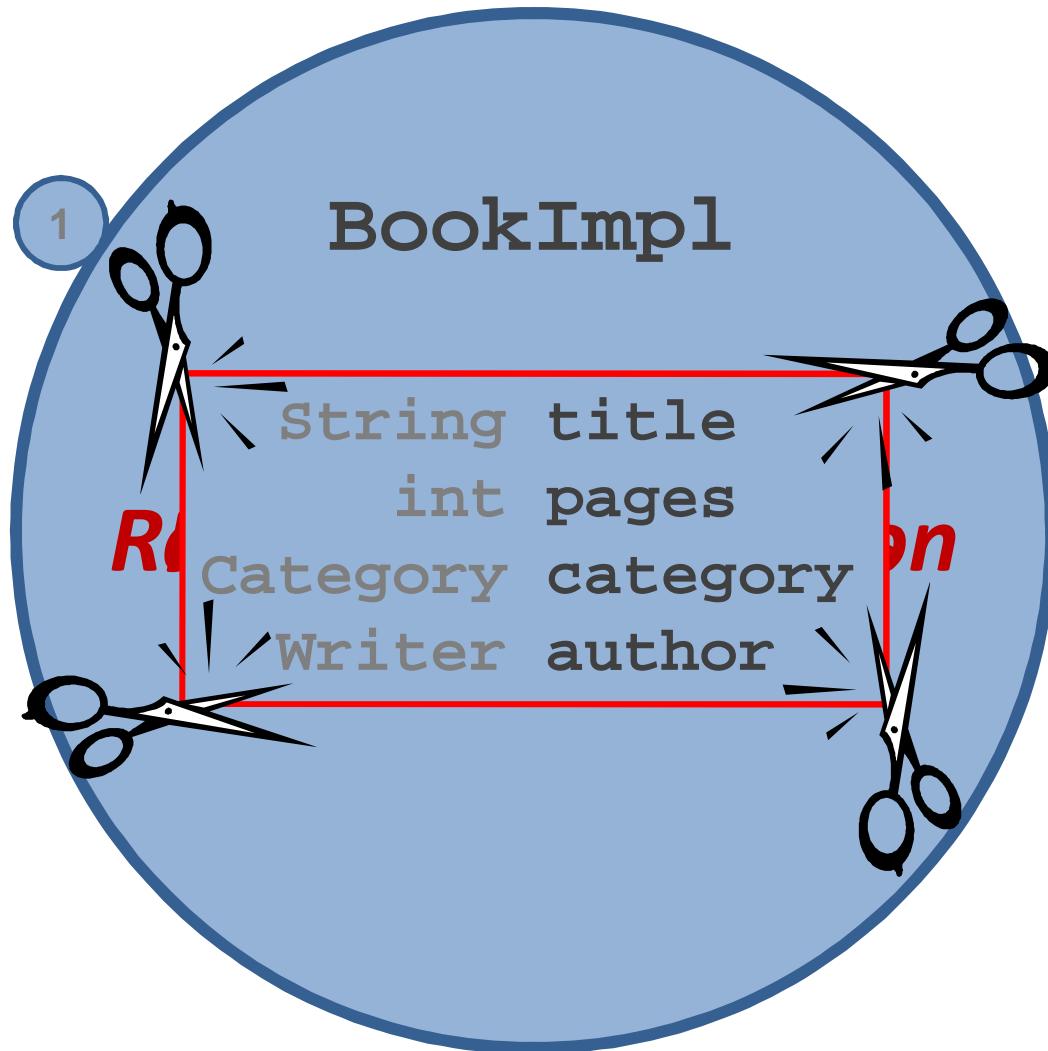

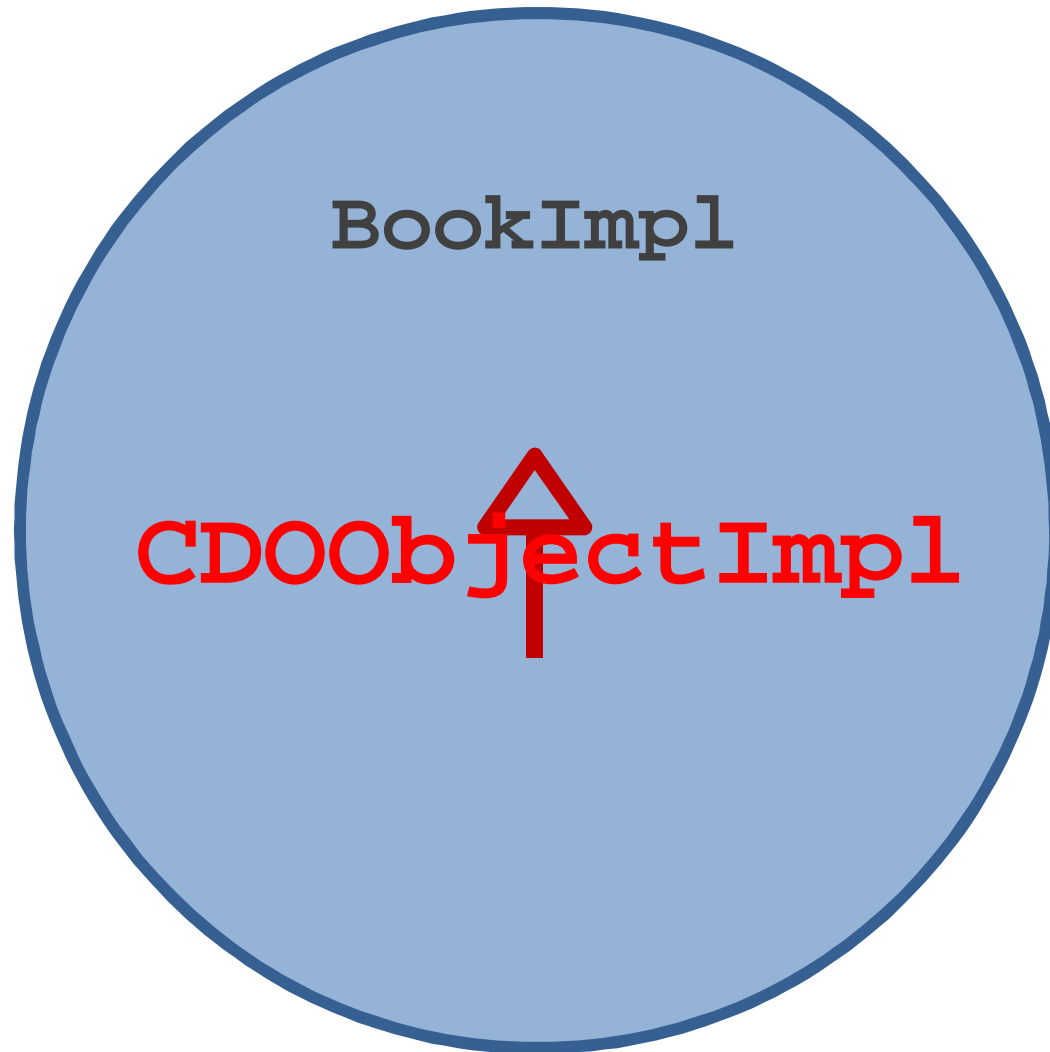

**CDOObjectImpl**

CDOID

CDORevision

CDOState

CDOView

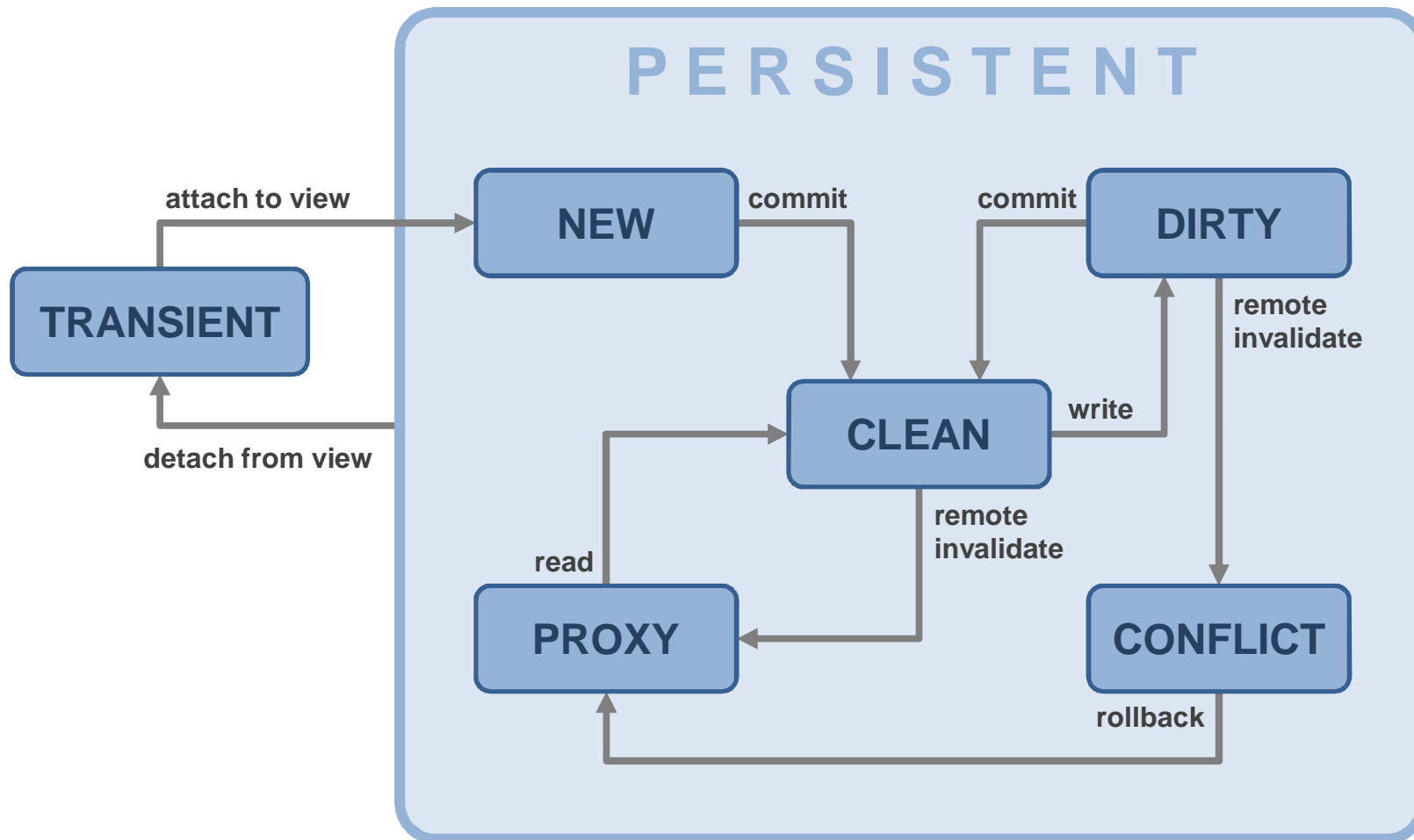

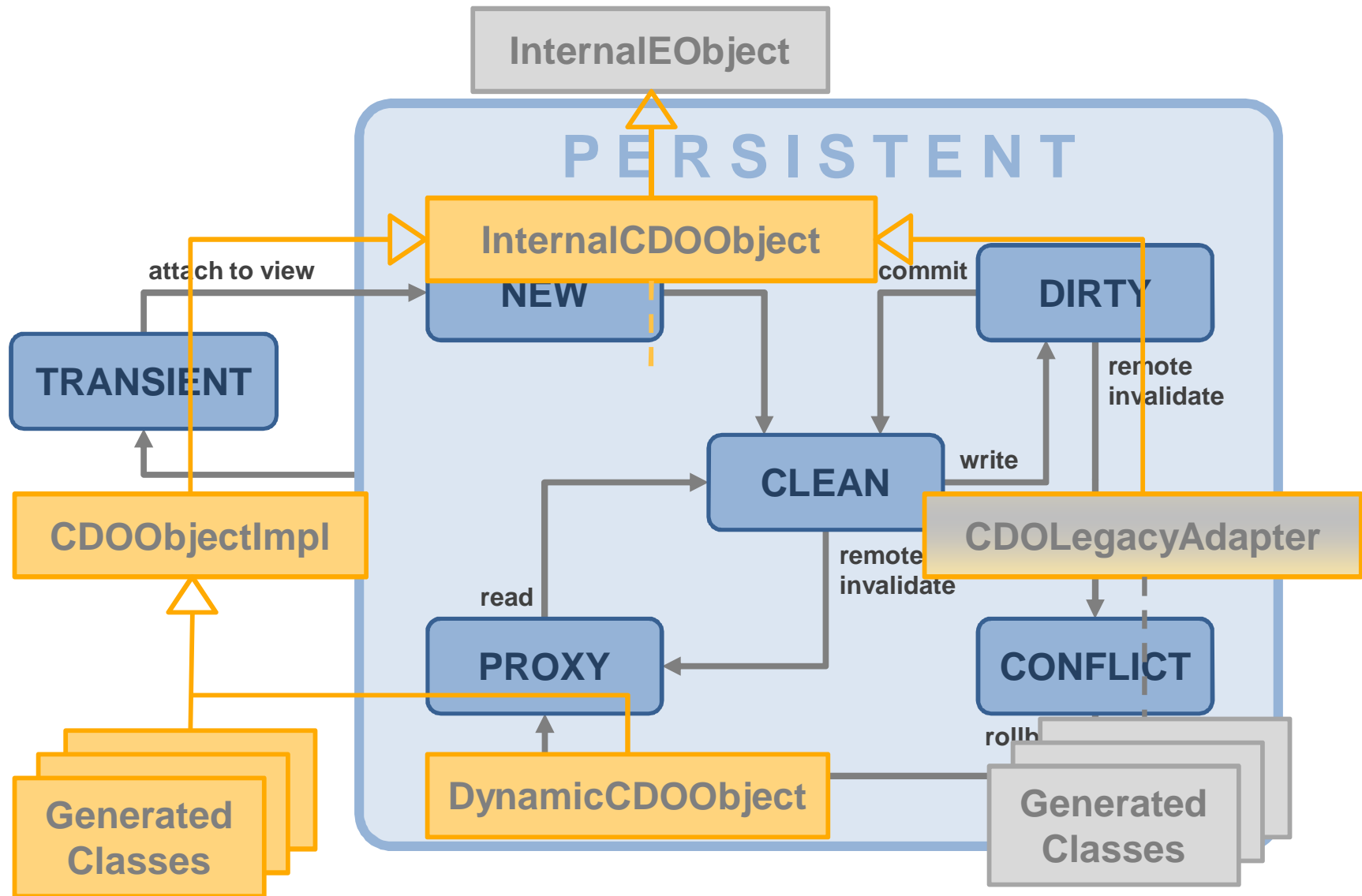

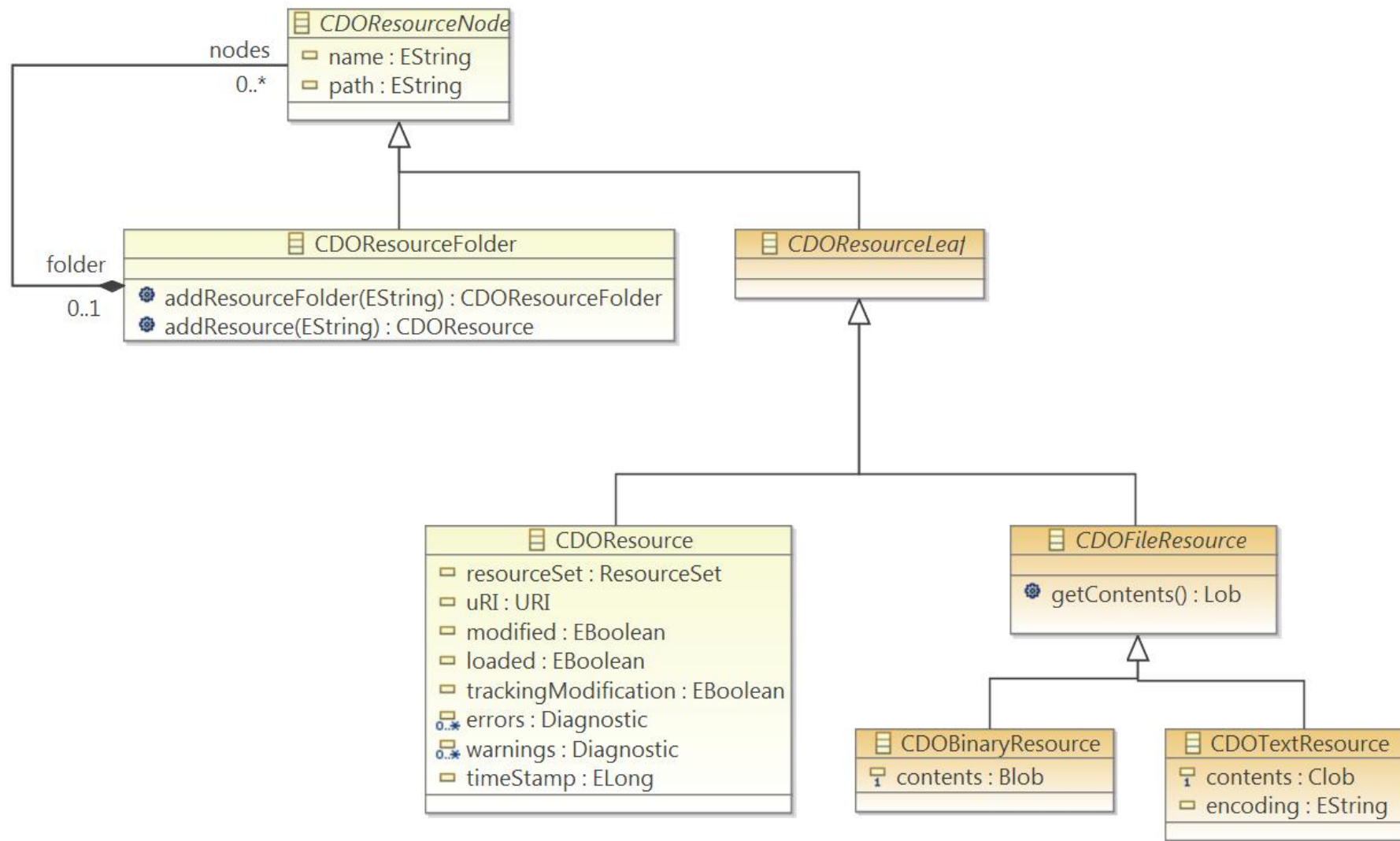

# Thank You

Please evaluate this session...